

UNITED STATES DEPARTMENT OF AGRICULTURE

SOIL CONSERVATION SERVICE

NATIONAL ENGINEERING HANDBOOK

SECTION 16

DRAINAGE OF AGRICULTURAL LAND

CHAPTER 2. DRAINAGE INVESTIGATIONS

	<u>Contents</u>	<u>Page</u>
General		2-1
Existing data		2-1
Aerial photographs		2-1
Maps		2-1
Surveys		2-1
Miscellaneous data		2-2
Soil Conservation Service experience in particular areas		2-2
Relation of flood hazard to drainage feasibility		2-3
Adequacy of outlet for drainage improvement		2-3
Basic requirements		2-4
Special outlet conditions		2-4
Tidal influence		2-4
Pumping		2-4
Dikes and floodgates		2-5
Economics of drainage projects		2-5
Classification of Investigations		2-5
Reconnaissance		2-5
Field reconnaissance		2-5
Detailed reconnaissance		2-6
Objectives		2-6
Recommended procedure		2-7
Preliminary Survey		2-8
Objectives		2-8
Recommended procedure for preparation of survey outline		2-8
Preliminary design and estimate		2-9
Preparation of plans and estimates		2-10
Design Survey		2-11
General		2-11
Data required for design		2-12
Investigations for Surface Drainage		2-13
General		2-13
Vertical Control		2-13
Topography		2-14
Soils investigations		2-15

Soil classification	2-15
Soil surveys	2-15
Investigations for channel stability	2-15
Land use and cropping pattern	2-16
Precipitation, runoff, and stream stage records	2-16
Location of mains and laterals	2-16
Profiles and cross sections	2-17
Recommendations for additional information and construction requirements	2-18
Investigations for Subsurface Drainage	2-18
General	2-19
Surveys and investigations required	2-19
Topographic surveys	2-20
Soils investigations	2-21
Subsurface explorations	2-21
Logging soils and subsurface materials	2-22
Soil samples for laboratory testing	2-24
Hydraulic conductivity	2-27
Auger-hole method	2-28
Equipment for auger-hole method	2-29
Formulas for determination of HC by auger-hole method	2-33
Other methods for determining hydraulic conductivity	2-34
Ground-water investigations	2-34
Observation wells	2-34
Size of wells and casing	2-34
Spacing	2-37
Depth	2-37
Establishing well elevations	2-37
Measuring water table levels and recording data	2-37
Period of measurement	2-39
Piezometers	2-39
Installation by driving	2-43
Installation by jetting	2-43
Batteries of piezometers	2-45
Salinity of ground water	2-45
Irrigation practices	2-45
Investigation of existing systems of buried drains	2-45
References	2-47

Figures

Figure 2-1	Sample form for soil log	2-23
Figure 2-2	Check list for fine-grained and partly organic soils	2-25
Figure 2-3	Check list for coarse-grained soils	2-26
Figure 2-4	Symbols for auger-hole method of measuring hydraulic conductivity	2-28
Figure 2-5	Equipment for auger-hole method of measuring hydraulic conductivity	2-30
Figure 2-6	Auger-hole method of measuring hydraulic conductivity	2-31
Figure 2-7	Hydraulic conductivity--auger-hole method by Ernst Formula	& 2-32
		2-35
		& 2-36

Figure 2-8	Example of field sheets for well and piezometer records	2-38
Figure 2-9	Max-min well gage	2-40
		& 2-41
Figure 2-10	Example of field sheet for piezometer log	2-44

Appendix A

Typical Outline for Preliminary Survey (Following page 2-48)	2A-1
--	------



NATIONAL ENGINEERING HANDBOOK

SECTION 16

DRAINAGE OF AGRICULTURAL LAND

CHAPTER 2. DRAINAGE INVESTIGATIONS

General

Drainage projects require survey and investigation of site conditions and study of historical data to determine their feasibility and for design. The extent of investigation required for each project depends on the investigator's experience in the area and the amount of data already available. Where the project is small and problems and their solutions are obvious, investigations and surveys may be limited to field checking at the site. Larger or complex projects will require more intensive investigations.

This chapter provides guidelines for determination of the extent of investigations needed under various conditions and describes procedures for making them.

Existing data

Use of existing data, such as maps, plans, and records, and the experience of trained personnel saves considerable time in the investigation of drainage projects. Available data relating to local drainage problems should be obtained, evaluated, properly identified, and assembled for use. Local SCS personnel should become familiar with these data in order to make the maximum use of it. Some types of data helpful to drainage work, and which should be available locally, are discussed below. The source of supply of the data is indicated.

Aerial photographs

Standard 4- and 8-inch per mile prints are usually available through the local SCS work unit. The more up-to-date they are the more useful they will be. Mosaics may be needed on larger projects. Photos in USDA-SCS county soil survey reports, particularly in those recently published, are valuable aids.

Maps

Maps which show detailed and recent topographic data are the most valuable. Quadrangle maps of the U. S. Geological Survey (USGS), Corps of Engineers (CE), Bureau of Reclamation, Tennessee Valley Authority, or other federal or state agency may be available. Local irrigation or drainage districts or private engineering firms often have useful maps which may be obtained. USGS maps are available from the U. S. Geological Survey, Denver, Colorado or Washington, D. C. CE maps are available from the District Engineer of the District which made the map. An index of maps is available from the USGS.

Surveys

Old drainage surveys and maps are often available and generally contain useful information. These are usually available through the drainage district, county clerk or county engineer.

Soil, geologic, ground water, and topographic surveys are helpful in drainage work. Benchmark surveys made by the U. S. Coast and Geodetic Survey, USGS, Corps of Engineers, Bureau of Reclamation or other federal or state agency are valuable. Vertical control for large group or district enterprises should be tied to standard benchmarks, based on mean sea level datum wherever practicable.

Miscellaneous data

Records and reports of value may include: reports of surveys listed above; soil conservation district programs and work plans; standard soil survey reports; precipitation, streamflow, river stage, and tidal records; and crop yield data.

The following publications will be of particular interest:

1. "Rainfall Frequency Atlas of the United States" - U. S. Department of Commerce, Weather Bureau - Technical Paper No. 40, May 1961, and Technical Paper No. 43, 1962 for Hawaii.
2. Two- to Ten-Day Precipitation for Return Periods of 2 to 100 years, U. S. Department of Commerce, Weather Bureau, Technical Paper No. 49, 1964 for the contiguous United States, Technical Paper No. 51, 1965, for Hawaii, and special precipitation records for mountain states.
3. Location of hydrologic stations, including those measuring precipitation, and river gaging stations are shown in "Notes on Hydrologic Activities Bulletin No. 11" compiled under the auspices of the Inter-Agency Committee on Water Resources, Subcommittee on Hydrology, April 1961. This is available through the National Weather Service.
4. Tide Tables, compiled by the U. S. Coast and Geodetic Survey, are available from that agency's Washington office. The volume for the Atlantic and Gulf Coast is "Tide Tables, East Coast, North and South America (including Greenland)" and for the Pacific Coast, "Tide Tables, West Coast, North and South America (including Hawaiian Islands)." These are published annually.
5. Data on benchmarks established by federal agencies are available on request from their local district headquarters or the Washington office. Requests should specify the locality for which the information is desired.
6. State Laws - requirements of state agencies for project development, clearance, etc. should be known.

All data should be evaluated for currency, accuracy, and application to the problem area, and it should be identified as to source and date of procurement. Also, after evaluation, the results of the evaluation should be clearly stated, dated, and signed by the evaluator. Limitations on use of the data should be specified.

Soil Conservation Service experience in particular areas

To take advantage of experience gained by working in a particular area use the SCS "Drainage Guides" which describe problems of drainage on certain soils within particular areas, investigations required, and the general criteria for design of remedial measures.

Before the different kinds of problems encountered in agricultural drainage are recognized, a good knowledge of soils, hydrology, hydraulics, and agricultural economics is needed. The effects of excess water and salinity on plant growth must be understood. Types of problems encountered in drainage work and principles of dealing with them are discussed in Chapter 1. Details of remedial measures are in other chapters which cover the particular type of drainage.

Relation of flood hazard to drainage feasibility

When investigating drainage problems it is important to determine if the area is subject to flooding and the frequency and character of the flooding. Floods may be so frequent and damaging that, without their prevention, drainage of the project area would not be feasible.

The principle of drainage design is to remove excess water from the surface of the land and/or from the root zone of the crop, before it causes damage, and to create a more favorable environment for the desired crops. There are periods in the growth of some crops when flooding should be held to as short a time as possible, but it is usually not feasible to attempt to contain all runoff from the less frequent rainfall events within ditch banks without any overland flow.

In evaluating the effects of flooding on flatland areas the following factors should be considered:

1. Frequency of damaging floods.--The frequency of damaging floods under which agricultural land can be operated profitably will vary according to the kind of crops to be grown, productivity of the land, the cost of preventing such floods, and other economic factors. If damaging floods can be expected more often than once each 3 to 5 years an economic evaluation for determining feasibility of the project may be required.
2. Depth and duration of flooding.--Flooding to shallow depths for a short duration may not be damaging. In many areas it has been determined that water standing 6 inches deep for periods up to 24 hours usually is not damaging to field crops. Truck crops and other crops sensitive to excess water usually require a more rapid rate of water removal. Most pasture, and riceland in rotation with pasture, can withstand longer periods of flooding without damage.
3. Time of flooding.--During the season when crops are not being grown, damage by flooding on flatland may be limited to scour of the flood plain, deposition of sterile materials, and/or property damage. Under some conditions floods may benefit land by deposition of topsoil and nutrients.
4. Erosion and/or sedimentation.--If flooding in a particular area is likely to cause serious erosion, the feasibility of drainage improvement is questionable. If sedimentation is excessive, methods to control it should be investigated. Such measures as diversions, dikes, and debris basins may be indicated. Flood plain scour or excessive sedimentation expected may make the project feasibility questionable.

Adequacy of outlet for drainage improvement

Drainage improvements should be continued to an adequate outlet. Generally, improvements to a drainage system will increase the peak discharge for the more frequently recurring storms. The increase will vary according to the ratio of ditch capacities after improvement to their capacities before improvement. The effect which this increase in peak discharge has on stages of water in the outlet depends on the relation of the size, shape, and hydrologic factors of the project area improved to the size, shape, and hydrologic factors of the watershed of the outlet above the point of discharge of the project system.

Effects of drainage improvements on water stages in outlets consisting of major rivers, large lakes, or tidewater may be considered negligible. Effects on outlets in flat lands, whose drainage area above the point of discharge of the project system is at least ten times the size of the project drainage area, also may be considered negligible.

Basic requirements

In determining adequacy of outlets the following basic requirements should be met:

1. The capacity of the outlet should be such that the design flow from the project will discharge at a stage elevation equal to or less than that required for adequate drainage of the land in the project. Where the project discharges into a natural or constructed channel, consideration should be given to the runoff from the entire watershed of the channel, which should be computed on the same basis as that used for the project area. The stage-discharge relationship of the outlet channel should be determined from records or by calculation.
2. The capacity of the outlet also must be such that the discharge from the project, after proposed improvements, will not result in stage increases in the outlet that will cause significant damages downstream.
3. The elevation of the water surface at normal low flow in the outlet should permit any needed subsurface drainage to be discharged.

The hydraulic gradeline for low water flow, from the outlet through the system of mains and laterals to the uppermost subsurface drain in the project, should be determined to insure that all needed drains can be discharged above it.

4. There should not be excessive scour or deposition of sediment in the outlet.

Special outlet conditions

Tidal influence. - Effect of the tides or littoral drift on discharge should be determined where improved channels discharge into rivers, estuaries, bays, and sounds subject to tidal influence. This should apply whether or not the outlet is reached through an automatic tide gate, or directly, without the benefit of a tide gate.

The characteristics and types of tides are discussed by H. A. Marmer in "Tidal Datum Planes," (1), and in Chapter 9 of this handbook. Where the drainage of agricultural land is affected adversely by tidal action it should be protected by a system of dikes and tide gates. Planning, design, and construction of dikes is covered in Chapter 6. Routing of specified flows through existing or proposed gates, in order to determine stage relations in the project area is covered in SCS Technical Release No. 1, "Routing Through Tide Gates," and in Chapter 9 of this handbook.

Pumping. - Where the project is provided with pumps for discharge of runoff from the watershed, the area usually is protected by dikes. In this case the dikes should meet the National Engineering Standard for dikes, the pumping capacity should be adequate for the design runoff, and the outlet into which the pumps discharge should meet the basic requirements for outlets.

Dikes and floodgates. - The area to be improved may be protected from flooding only by a system of dikes and floodgates. In such cases there is a question as to whether a pumping plant is needed to relieve temporary flooding within the protected area during periods when the floodgates are closed due to higher stages on the outside. This resolves itself into a check of coincidence of stages on both sides of the dike. A temporary reservoir is formed in the protected area, and a check is made of the frequency and duration of pumping required to remove water from the reservoir. The cost of the pumping plant required to relieve the temporary flooding within the protected area should be determined, including the cost of operation. This would be compared with the damage which could be expected due to flooding without the pumping plant. A study of the timing of coincident flood stages on both sides of the dike and the economic factors involved will provide the information needed to determine the feasibility of the pumping plant.

Economics of drainage projects

In all cases, recommended improvements should provide benefits in excess of costs. For large complex projects an economic analysis is needed to make the feasibility determination. For small jobs a comparison with similar work in the area, where benefits are well known, is usually enough to determine feasibility.

On large group enterprises, the analysis may be complex and require the assistance of an economist. There are various stages between these two extremes and the principles of good economic analysis should be followed. Reference should be made to the Soil Conservation Service's "Economics Guide for Watershed Protection and Flood Prevention," March 1964.

Classification of Investigations

Investigations for drainage work may be divided into three types depending upon the objectives and level of investigation required. These will be discussed here as:

1. Reconnaissance
2. Preliminary survey
3. Design survey

Since most jobs are somewhat different the investigations needed for each should be considered carefully. For the larger, more complex jobs a work outline usually is required to insure that the data needed is obtained in an orderly manner. Investigations for the smaller, frequently recurring types of jobs may be based on a standard procedure, which has been developed for the particular type of job and a similar set of site conditions. In any case, extraneous details and work not needed to meet a specific objective should be omitted.

Reconnaissance (Preliminary Investigation)

Field reconnaissance

A field reconnaissance of the drainage problem area is necessary to obtain as much information as possible, and to provide the basis for development of a work outline for additional investigations needed. The reconnaissance is usually an inspection of the area from easily accessible points. Parts of the watershed outside the drainage problem area, should be examined to determine runoff characteristics and land treatment needed for protection of the proposed

improvements. This reconnaissance may be supplemented by discussions with the owners and others who are familiar with the area.

For group enterprises where a report is necessary as a basis for determining feasibility of the job, group interest, and determination of SCS personnel time required to complete the job, a more comprehensive reconnaissance is needed. Under these circumstances the type of investigation usually required is on the order of that described as "Preliminary Investigation" in the Watershed Protection Handbook and as a detailed reconnaissance below.

Detailed reconnaissance

This is a streamlined type of investigation to determine the problems in the drainage area and the principal improvements needed, and to make a rough estimate of the cost.

Conditions applicable to a detailed reconnaissance are:

1. A P.L. 566 Watershed which it is known will be considered for planning priority by the Governor of a State or his designated state agency.
2. A group enterprise where the group is not well organized, interest level among some landowners is high, but some opposition may exist, and there is a need for a plan and cost estimate of the project before organization of the group can be completed.
3. A comparatively large and complex individual farm job where the owner needs an estimate of cost before he can commit himself to proceeding with the project.

Objectives

The objectives of a detailed reconnaissance should be to:

1. Determine the extent of the area needing improvement.
 - a. Type of improvements required should be determined: flood prevention, surface drainage, subsurface drainage.
2. Determine the adequacy of outlets for the needed improvements.
3. Develop a general plan for improvement:
 - a. Make an estimate of principal improvements needed.
 - b. If drainage ditches may be located through hardwood swamps, have forester to identify and evaluate timber in a general way.
 - c. Consider wildlife aspects of ditches through swamps. Priorities in maintenance of wildlife values and agricultural purposes should be determined at this stage.
 - d. Determine adequacy of organization to obtain needed rights-of-way. (For group enterprises only.)
4. Insure that the plan of improvement will meet the requirements of state law.

5. Make an estimate of the costs and benefits of the proposed improvements (where necessary).
6. Make a comparison of the costs and benefits and prepare recommendations to the members of the enterprise for the course of action to follow.

Recommended procedure

The following items are considered to be the minimum required. Modification may be needed for the project under consideration.

1. Assemble and evaluate existing data.
2. Prepare a work map of the project showing watershed boundaries, existing streams, old ditches and drains, physical features, and other pertinent information.
3. Obtain or develop a generalized soil and simple land use map of the project.
4. Determine status of any state, federal, or local program which will have an effect on the project.
5. Make an engineering reconnaissance of the project. Observe existing drains and ditches, bridges, topographic and farm conditions, and ground water levels.
6. Determine the adequacy of outlets for drainage improvements.
7. Make the following determinations by evaluating the information gained from the engineering reconnaissance, and the material listed in items 1, 2 and 3 above:
 - a. Develop a tentative plan of improvement.
 - b. Determine the approximate locations of the mains and principal laterals - evaluate adequacy of present locations.
 - c. Prepare cost estimate - consider clearing, excavation, spreading of spoil, erosion control, bridges, culverts and other structures, pipelines, etc.
 - (1) Mains and principal laterals.
 - (2) Minor lateral ditches and drains.
 - (3) Dikes, flood gates, pumping plant.
 - (4) Land, easements and rights-of-way.
8. Check the project cost estimate against costs for similar projects previously constructed. Modify unit costs to represent current costs. Allow for physical differences between projects.
9. Use an adequate contingency allowance in arriving at total cost estimate.
10. Estimate the benefits expected to accrue to the project after installation of proposed improvements. Compare the costs and benefits.

11. Prepare recommendations.

All data developed in the reconnaissance should be plotted on standard data sheets, properly identified and filed in a manner that it can be used most effectively in further work on the project.

Preliminary Survey (Engineering Survey for Watershed
Work Plan Investigations and Analysis)

This is a rather comprehensive survey, but lacking the detail required for preparation of construction plans. However, field data collected and recorded should be sufficiently accurate for use in design survey. Extensive field surveys and investigations are made, problems are located and remedial measures are planned, preliminary designs are made, and a reliable cost estimate is prepared. Ordinarily an economic evaluation of project feasibility is made. This type of survey should be made only after it is determined that interest of landowners is adequate to justify the surveys and that it is their intent to assume their financial obligations and overcome any minor obstacles and right-of-way problems.

Preliminary surveys are applicable to:

1. A group enterprise where the drainage problems are complex, the specific measures needed to correct the problems may not be readily apparent, a plan and cost estimate is needed to make arrangements for installation of the needed improvements, and an economic evaluation is needed to determine project feasibility. This includes P.L. 566 Watersheds and RC&D projects.
2. A group enterprise where kinds of needed improvements are known, landowners responsibilities for obligations are known and accepted, but a more detailed survey is necessary for bond issue or for federal assistance.

Objectives

The objectives of a preliminary survey are to:

1. Specifically locate areas in need of improvement - flood prevention, surface drainage, subsurface drainage.
2. Develop a comprehensive plan for improvement based on needs of the watershed and desires of the owners.
 - a. Select design criteria.
 - b. Locate and make preliminary design of all the principal features of the planned improvements.
3. Prepare estimate of quantities and costs.

Recommended procedure for preparation of survey outline

The specific surveys and investigations required to meet the objectives will vary according to the nature of the problems in the area. The procedure outlined below may be altered to meet the particular requirements.

In the preliminary survey, substantial field work is required, the results of which are then evaluated for completeness and accuracy, and data is plotted for use in design. A schedule of operations should be developed to insure that the various phases of the survey are completed as required. In projects where subsurface drainage is a problem it may be necessary to provide a time lag of several months for assembly of field data - other than the periodic reading of observation wells and/or piezometers after their installation and during the period when water table conditions are expected to be most significant.

After the reconnaissance of the project area by the engineer responsible for the survey, made with local personnel most familiar with the situation, the following procedure is indicated:

1. Existing data, pertinent to the problem area, should be obtained. Most of this will have been obtained during the reconnaissance. Careful evaluation of such data will usually save a lot of field work.
2. A survey outline should be prepared. This outline should cover the following items with respect to the specific needs of the area:
 - a. Objectives of the survey and investigation.
 - b. Inventory of available data which will be useful.
 - c. Additional data needed to meet the objectives.
 - d. Proposed plan of investigation.
 - (1) This may need to be expanded or revised as the survey progresses and requirements of the project are better known.
 - (2) The plan of investigation should be carefully worked out to use available routes of communication to the maximum extent possible and to obtain the essential information at the least cost.
 - e. Plan for evaluation of data and preliminary design.
 - f. Preparation of estimates and report.
 - g. Estimate of personnel required - unless the job is to be contracted.
 - (1) A deadline for completion of the survey should be established and types of personnel and time on the job scheduled in order to meet the deadline.
 - h. Equipment required - type and time on job - unless job is to be contracted.

A sample outline for a Preliminary Survey is given in Appendix A. This outline suggests procedures which are of the intensity normally needed for meeting the objectives of this type of survey. As work progresses it may be found that certain changes in the proposed investigations should be made in order to accomplish the objectives at the least cost. Changes in the outline should be made in the same manner as the original outline was developed.

Preliminary design and estimate

The preliminary design required as an essential part of this survey is based on

criteria contained in the chapter of this handbook which deals with the particular type of drainage. State engineering standards and local drainage guides for the practice should be followed. The data on which the design is based will not be of the intensity required for construction design and the design itself need not go into the detail required for construction. The need here is to obtain a design of the project which will permit the development of a cost estimate that will be within the required degree of accuracy. This is generally considered to be an estimate within 20 percent of the actual cost of improvement.

The following guidelines generally should be followed in order to obtain a sufficiently accurate estimate:

1. A preliminary design of all mains and laterals should be made which will permit estimation of quantities and costs within the tolerances discussed above.
2. Principal laterals for surface drainage are considered to be those with a drainage area of one square mile or more, and which are needed to remove excess water from land to be protected.
3. For subsurface drainage improvements all open ditches draining one square mile or more, and all group main drains should be included in features for which a preliminary design is made.

In addition to estimating quantities and costs for clearing and grubbing, excavation, spreading of spoil, installation of drains and appurtenant structures, and rights-of-way, all other items required for the drainage system should be included in the cost estimate. Costs for some of these items should be estimated on an individual basis because of their size and importance. These include: bridges, culverts, irrigation flumes and grade control structures in mains and principal laterals; dikes, pumps, and tide and floodgates. Other, less costly items, may be estimated on a sampling basis. These include erosion control structures for side-water inlets, watergates for cross fences, and vegetation of ditch banks and critical erosion areas.

Preparation of plans and estimates

The plans for proposed improvements should be as complete as the data accumulated will permit. Plans and estimates prepared as a result of this survey will frequently form the basis for development of watershed work plans, issuance of bonds by drainage districts, or other large scale drainage operations. They should meet all Service standards for technical excellence and clarity. Data developed for these plans can be used in preparation of final design and should be carefully marked in the field and on the notes.

The following items should be included in the plans developed:

1. Map of project area showing proposed improvements. The map should show the following features:
 - a. Location of all mains and laterals which were surveyed. Laterals which are proposed but not specifically located should not be shown on the map.
 - b. Drainage area boundaries of mains and laterals.

- c. Existing land use, roads, railroads, towns, public utilities and pipelines, irrigation facilities, bridges and culverts which are proposed to be built or rebuilt, apparent property lines, and other structures or items which are specifically located.
 - d. Pumps, dikes, floodgates, etc. where applicable.
 - e. Any other features which will affect the drainage plan.
2. Profiles and cross sections - Profiles and cross sections of all mains and laterals surveyed should be included. Profiles should show normal ground elevation, spot elevations in field, existing and proposed ditch bottoms, design hydraulic gradeline, and bridge, culvert, and grade control structure elevations and dimensions. The elevation of the water stage in the outlet, after installation of project improvements, for the frequency of storm used for design, should be determined and shown on the profile of the main ditch.

Cross sections should show existing and proposed sections of channel, berm, and related dike or spoil bank; existing and proposed culverts and bridges, including deck, abutments, piers, and footings; and computation of earthwork quantities.
 3. Typical layouts of on-farm drainage systems recommended and used in making cost estimates.
 4. Typical plans for structures required for admitting runoff water to mains and laterals to prevent erosion, and for other structures needed.
 5. Hydraulic computations for channel or floodway design.
 6. Estimates of quantities and costs. These should be broken down by major items of work to the extent that any separate group or agency concerned with the project will be able to identify their obligations for installation.

Design Survey

General

Design surveys are those required for preparation of construction plans and specifications.

This type of survey is indicated:

1. After the reconnaissance and/or preliminary surveys have served their purposes and the owner or group has made the necessary financial and rights-of-way arrangements to proceed with the project, and further detailed surveys and investigations are needed to prepare construction plans and specifications.
2. For an individual farmer or small group in an area where Service experience in similar types of work has previously been obtained and there is no question as to project feasibility or the willingness and ability of the owners to obtain rights-of-way and finance the work.

Prior to construction of any drainage project, surveys and investigations should be made which show existing topography, structures, soil, ground water and hydrologic data needed for detailed location and design of all features to be included in the project. Maximum use should be made of data obtained in prior surveys. Additional data will usually be needed to prepare the necessary plans and estimates. For many small jobs the design survey may be the first and only survey to be made.

Data required for design

Data on hand should be evaluated and a determination made as to the amount of additional data needed for construction design. Depending on the age of existing data it may be necessary to make a random field check to verify it. For complex or unusual jobs it usually is necessary to prepare a survey outline as a guide to obtaining additional information. The following list covers the data usually required for design. Some of this usually will be available from previous investigations. This may be adapted to local conditions and a standard operating procedure (SOP) developed for obtaining it.

1. Delineate the problem area. Use soils map, supplemented by deeper borings, field observations and discussion with owners. Examine water table records for fluctuations, if available, and where subsurface drainage is needed determine if the problem area has been adequately defined.
2. For large projects ground water or piezometric contour maps should be made to show seasonal changes.
3. Determine extent, frequency, and seasonal flooding of the problem area and if the outlet is adequate.
4. Determine land use and crop requirements for drainage and any proposed changes in cropping pattern. (At this stage of project development all objectives to be obtained through drainage should have been defined.)
5. Obtain topography of the problem area, and select the location of all mains and laterals, interceptor drains, relief drains, and pipelines to accomplish project objectives.
6. Delineate drainage areas of all mains and laterals (open ditches) and all subsurface drains, which are a part of the project.
7. Survey and plot profiles and cross sections, adequate for design and estimation of quantities.
8. Make geologic and ground water investigations and obtain required testing to determine channel stability where necessary. SCS Technical Release No. 25, "Planning and Design of Open Channels," contains guidelines for this. Plot geologic ground water and test data on the profiles and cross sections where applicable.
9. In addition to items in 5 above, determine all other improvements needed, such as bridges, culverts, grade control structures, surface water inlets to buried drains or to open ditches, dikes, floodgates, pumping facilities, and all other structures and appurtenant facilities to fully meet the project objectives. Obtain necessary information for hydraulic, foundation and structural design of each feature.

10. Develop construction specifications for all items of work included in the plan. (Use standard specifications where applicable.)
11. Estimate needs and approximate costs of on-farm facilities - not included in the project improvements - such as land grading, land smoothing, drainage field ditches, buried drains, pumps, and other drainage structures.
12. Estimate quantities and costs for all features of the project.

Investigations for Surface Drainage

As previously discussed, the engineer responsible for design of a project must decide the kind and intensity of surveys and investigations which are needed for planning, design, and evaluation of the project which will meet the objectives of the owners. Where needed, an outline should be developed which lists in detail the factors to be considered, and the kind and intensity of surveys and investigations to be made. The kind of investigations needed for surface and subsurface drainage are different and will vary in different parts of the country.

In some areas the main problem will be surface drainage, and in other areas - subsurface drainage. In most situations, however, where drainage is a problem, it is necessary to investigate both surface and subsurface conditions. Investigations required for each type must be determined by the responsible engineer and the survey planned accordingly.

General

Surveys and investigations usually required for planning and design of surface drainage improvements are:

1. Topographic surveys.
2. Soil surveys and delineation of critical erosion areas.
3. Determination of land use and cropping pattern.
4. Precipitation and runoff investigations.
5. Stage-frequency investigation of high water in outlets, including tidal and lake level fluctuations where these are involved.
6. Profiles and cross sections of existing streams and ditches.
7. Geologic investigations and required testing for channel stability, where needed.

When preparing an outline for a particular survey the needs for future more intensive surveys should be kept in mind. Quite often a little extra work on a preliminary survey will save a lot of time later when making the design survey. Setting temporary benchmarks for future use, and to the degree of accuracy required for construction design, is an example of things which can be done when making preliminary surveys that will save time and expense later.

Vertical control

The survey for surface topography requires accurate differential leveling. A high degree of accuracy is required because gradients are usually quite low and

small differences in elevation are important. Usually a system of temporary benchmarks is established over the problem area as the first step in obtaining topographic and other data based on differences in elevation. Survey outlines and standard operating procedures should specify the accuracy to which elevations of temporary benchmarks (TBM's) should be checked. TBM's established during the preliminary survey should be numbered and identified so they can be used in making the design and construction layout surveys. Where a Coast and Geodetic Survey or Corps of Engineers benchmark is available within a reasonable distance from the problem area, vertical control should be based on the datum of the benchmark. In large watersheds it is helpful to prepare location maps of existing benchmarks. This may be done on an existing county highway or similar type map. Additional benchmarks and temporary benchmarks should then be established at convenient locations over the project area.

Topography

Information on the topography of the drainage problem area is essential. The topographic map should show all physical features, both natural and man made, which affect design of the drainage system. It should be in the detail necessary to locate existing drainageways and the drainage area boundaries. The detail of the topographic information required for planning and design of group enterprises and that required for on-farm field drainage is quite different. Minor differences in elevation within a field are not important to planning or design of ditches which are to serve a larger area. These minor differences are important, however, to the design of the field drainage system, which may include land grading, field ditches, row direction, etc. Good judgment is needed to determine the extent of topographic data needed for a particular purpose, and contour maps developed which will show the detail required for development of the plan. The flatter the topography is, the smaller the contour interval should be. These maps should be supplemented when necessary by spot elevations of isolated critical points, when these are evident and will fall between contour intervals.

In addition to surface contours, the location of ditches, roads, railroads, pipelines, other utility lines, farm boundaries, land use, section lines, boundaries of drainage enterprises, and other features, which may affect the plan for improvement, should be shown on the map. Quadrangle maps of the U. S. Geological Survey, Bureau of Reclamation, or Corps of Engineers will give a great deal of this information. It usually is necessary to supplement this data with information from aerial photographs and field surveys.

Field surveys are made in various ways according to customs of the engineer, equipment available, and detail required. The planetable with telescopic alidade is excellent for obtaining detailed topography. Transit surveys for both horizontal and vertical control are used in many cases. A common method of obtaining topographic data is to use aerial photographs for horizontal control and an engineers' level to obtain elevations.

Chapter 1, Engineering Surveys, of SCS Engineering Field Manual for Conservation Practices is a good manual on surveying. It should be consulted for guidance on practices and procedures. Standard notekeeping procedures, and requirements for accuracy, clarity, and identification should be followed. Survey data should be recorded and filed in a way which will facilitate its use in subsequent surveys - as well as for the one being made. Notekeeping procedures specified in Engineering Memorandum SCS 39 should be followed.

Soils investigations

The best soils map available should be used in drainage investigations. For surface drainage the standard soil survey usually is adequate for planning purposes. It will be necessary to obtain logs from some deeper borings to determine soil stability, permeability, and barriers which would affect channel construction. In some areas logs from deeper borings are necessary to obtain depths and types of compressible organic soils. For large complex jobs use the investigation procedures of NEH-8, Engineering Geology.

Soil classification

Standard soil surveys use the USDA Comprehensive Soil Classification System. Soil texture is recorded for every horizon. Conservation planning and determination of surface drainage needs are based on this classification.

In SCS construction operations, however, the Unified Soil Classification System is used. This is described in ASTM Designations D 2487 and D 2488. Use of the two systems of soil classification requires engineers and other technical personnel who work with both planning and construction to learn both systems and the areas where each is applicable. For example, on a surface drainage job the standard soil survey with USDA textural classification is used to describe soil profiles to shallow depths. The Unified Soil Classification is used for deep borings. Each system has characteristics which make it adaptable and useful for its particular purpose.

Soil surveys

The standard soil survey usually is available for design surveys but for some preliminary surveys a less detailed survey may suffice after field checking site conditions.

Information on the soils map will indicate those areas which have inadequate drainage and the degree of inadequacy and which require follow up investigations.

Investigations for channel stability

The standard soil survey usually will furnish information on soil stability adequate for design of ditches four feet deep or less. For deeper ditches, and some soil conditions, more detailed information is needed on soil strata to a depth below planned excavation of about one-half the proposed depth of ditch. This must be obtained from test holes along the route of the proposed ditch. The Unified Soil Classification System should be used for identification of material obtained from the test holes. Test holes should be dug, drilled, or bored initially at 500-foot intervals, and if correlation of material from holes is good, the spacing may be extended. If correlation is poor, the interval between holes should be decreased. The survey outline should specify the initial spacing and depth for obtaining soil logs. Knowledge of the complexity of geologic and soils distribution in the area is helpful in determining the amount of subsurface investigation required.

Data is needed on soil materials to determine design requirements for channel stability. Observations and records of side slopes and stability of existing channels in similar soils in the same area provide guides for determining the limits for side slopes and velocities for design purposes. The depth to a water table encountered in test holes should be determined and areas of unstable soils where the water table will be above the bottom of the proposed ditch should be located, as this will cause sloughing and other construction problems. Barriers of shale or rock which would not classify as common excavation to the required depth of channel should be located and identified. Results should be shown on the channel profile sheet.

Land use and cropping pattern

Land use can ordinarily be obtained from recently made aerial photographs. It may be necessary to check this in the field. The cropping pattern on cultivated land is needed to select proper rates of drainage and to make the economic evaluation. Data is needed for conditions prior to improvements and for proposed changes after project installation. This information can be obtained from individual landowners.

Precipitation, runoff, and stream stage records

Most of the available data on precipitation is published by the National Weather Service, and that for stream stages and discharge by the Geological Survey. Records pertaining to the area involved should be available for use. This information is needed to determine flooding conditions in the project area, capacities of existing streams, and adequacy of outlets for drainage improvements. In areas where drainage coefficients or pumping requirements have not been established the hydrologic factors will be needed to help establish them.

Location of mains and laterals

Prior to running levels for profiles and cross sections the main ditches and laterals to be included in the plan should be located on aerial photographs or topographic maps of the project. Each should be identified in such a manner that it can be easily referred to and located. It is desirable for laterals to be designated in a manner which will identify them with their outlets. One way to identify main ditches by Roman numerals and laterals which empty into them by this numeral followed by a capital letter. For instance, the first lateral above the outlet of Main No. I would be Lateral IA; and the second lateral would be IB. This could be extended on to the sublaterals by going into arabic numerals and lower case letters. Stream names should be used also, where the local name is known. Thus:

Main No. I, Cypress Bayou
 Lateral No. IA, Muddy Slough
 Lateral No. IA1
 Lateral No. IA2
 Lateral No. IA2a
 Lateral No. IB, Hickory Draw
 Lateral No. IB1
 Lateral No. IB1a
 Lateral No. IB1b
 etc.

Location of ditches may be made from information on topographic maps or aerial photographs as supplemented with information obtained by field observation and property ownership maps. Considerations which govern the location and proper alignment of ditches appear in Chapter 5. Good alignment of mains and laterals is most important. A lot of thought and effort is fully justified in order to obtain the best alignment possible for the particular site conditions. After tentative locations of main ditches and laterals have been drawn on the photograph or map - often called "paper locations" - centerlines are located on the ground. If actual field location is different from the tentative map location, the map location should be changed to correspond with field location. The centerline on the map is scaled, and stations are marked for future use. When improving the alignment of ditches, care should be taken that the hydraulic grade line is not increased to the extent that the resulting velocity will cause a

stability problem in the ditch. When making design surveys in many locations it is necessary to use a transit or compass to establish the centerline of ditches. The centerline is staked at intervals of 100 feet or greater, depending upon the regularity of the ground surface and the alignment of the ditch. This may require use of an offset line if the proposed centerline is inaccessible or vision is obscured by trees or brush. Where the location is open and is not rigidly fixed by easement or other legal description, the engineer can stake out the centerline reasonably close with the use of range poles. This method often gives a sufficiently accurate alignment.

See Chapter 5 for recommendations as to use of simple curves and minimum radii in establishing alignment for mains and laterals.

Simple curves may be located with a transit and tape or with only a tape. A high degree of accuracy is not required. A field manual containing tables of functions of a 1-degree curve and formulas for solving problems in field location of curves will be helpful.

Refer to Chapter 1, Engineering Field Manual for Conservation Practices, for methods of staking curves.

Profiles and cross sections

Before obtaining profiles and cross sections of existing streams and ditches in the project, it is necessary to establish vertical control over the problem area by the network of temporary benchmarks described under Vertical control, page 2-13. The outline for the survey, whether it is to be a preliminary or design survey, should specify the manner in which the profiles and cross sections are to be obtained. In some cases it may be desirable to run lines of levels adjacent to the drainageways to be surveyed, taking profile readings and cross sections at predetermined intervals. This is usually done for design surveys and may be used for preliminary surveys. For preliminary surveys it may be desirable to run lines of differential levels at approximate right angles to the direction of drainage and across the problem area, at predetermined spacings, taking a ditch cross section wherever a line of levels crosses a drainageway. In the latter case, maximum use should be made of existing roads, railroads, and utility line rights-of-way for running lines of levels.

The distance between cross sections on a particular stream or ditch will be governed by the type of survey and the uniformity of the drainageway. In making a reconnaissance, few cross sections will be needed. In preliminary surveys the interval between cross sections may vary from about 500 feet to one mile, depending on uniformity. This would be in addition to obtaining cross sections at all existing bridges, side channels, etc.

In design surveys, profile readings and cross sections are taken at intervals of 100 to 1,000 feet along the established location, depending on the topography. Cross sections should be taken at topographic breaks in order to obtain accurate yardage. Where existing ditches, natural streams, or depressions occur, profile readings should be taken on normal ground along the low side of the ditch. Cross sections should extend far enough on either side of centerline to reveal the field elevation and changes in topography having a bearing upon the design, construction, and function of the proposed ditch. Low areas, important and large enough to be control points, should be located and their elevation and approximate areas obtained. Good judgment is necessary to obtain sufficient cross sections to meet standards of accuracy for yardage determination without doing an excessive amount of surveying.

When obtaining profiles and cross sections, surveys should originate and terminate on temporary or permanent benchmarks of known elevation. Additional TBM's should be set as needed, and located so as not to be destroyed by clearing operations. Turns should be made through all TBM's.

Recommendations for additional information and construction requirements

As surveys are made for the specific items listed, notes should be kept of any feature which will affect design or construction. Roughness coefficients of existing channels, which could possibly be used, should be noted. Clearing and grubbing required should be located and identified. Pipelines, other utility lines, fences, access roads, stability of existing ditches, etc. are items which will have a bearing on design and construction, and may have a significant effect on economic feasibility of the project.

The size and adequacy of existing bridges and culverts should be determined. The structure should be described and elevations obtained of the inverts of culverts, bottom of stringers of bridges, and road surfaces. The condition of the super-structure, foundation, piers, piling, abutments and footings should be determined where applicable.

When buildings are located within the area which may be affected by construction of the project, their location should be accurately established, and the structural stability of the building and its foundation determined.

Recommendations for all specific practices and features needed to provide a completely adequate drainage system should be passed on from the field survey party to the design engineer. The surveys and investigations are adequate only if the field engineer obtains the information required to design all features needed. Wherever possible the design engineer should make a personal reconnaissance of site conditions.

Investigations for Subsurface Drainage

Certain investigations are required for all drainage projects. These include mapping the topography, soils, present land use and cropping pattern; study of precipitation, evapotranspiration, runoff, and streamflow records pertinent to the area; and making profile, cross section, and soil profile investigations for open ditches. Geologic and ground water investigations are made as needed. Techniques for making these investigations are discussed in this Chapter under "Investigations for Surface Drainage," and in NEH Section 8, Engineering Geology. These methods of investigation are applicable to all parts of the country and to irrigated areas as well as non-irrigated areas.

In addition to the investigations required for all drainage projects there are some which are needed to furnish information on areas where preliminary investigations have indicated a need for subsurface drainage. Investigations for this purpose are covered in this section. These differ from those for surface drainage, as it is necessary to obtain information on ground water, perched water tables, salinity, and conditions below the upper soil horizons in addition to most of the information previously listed as needed for surface drainage. Ground water moves both horizontally and vertically through the soil and subsurface materials; therefore it is necessary to obtain information on the permeabilities of these materials. Permeabilities vary with the type of soil or subsurface materials and with the structure and the texture. Therefore it is necessary to investigate these to the extent that they have an influence on drainage. In summary, subsurface drainage investigations involve most of the items pertinent to surface drainage plus more detailed information on soil, subsoil and ground water conditions.

Additional information may be obtained from the "Guide for Investigation of Subsurface Drainage Problems on Irrigated Lands" published by the American Society of Agricultural Engineers (2).

General

Objectives of investigations for subsurface drainage are:

1. Inventory of project site conditions.
2. Diagnosis of the causes of excess ground water and/or salinity.
3. Determination of the appropriate remedial measures.
4. Procurement of data required for establishing the pattern, size, depth and spacing of the drains, outlet requirements, and for design of such auxiliary ditches, diversions and appurtenant structures as are needed.

The usual causes of excess wetness in humid areas can often be assessed in the reconnaissance of the project and will usually conform to one of the categories of site conditions discussed under "Subsurface-drainage problems" in Chapter 1. In some situations, particularly where rock outcrops or artesian pressure are evident or suspected, investigations to locate the source of wetness and to determine methods of correction are necessary.

The majority of subsurface drainage needed in the arid and semi-arid regions of the United States is within irrigated areas. There is a close relationship between irrigation and drainage in these areas. The amount of drainage water to be removed by subsurface drains is related to the irrigation water applied and, to some extent, the irrigation methods practiced. The physical information and data required for drainage is in part the same as that required for irrigation. Data on permeability, consumptive use, water quality, salinity, water table levels and surface topography are needed for both the practices of irrigation and drainage.

Surveys and investigations required

Surveys and investigations usually required for subsurface drainage include the following:

1. Topographic surveys
 - a. Detailed topographic surveys
 - b. Partial or strip-topography
2. Soils investigations
 - a. Standard soil survey maps
 - b. Data on salinity and alkalinity
3. Subsurface explorations
 - a. Logs of soil and subsoil materials
 - b. Hydraulic conductivity measurements

4. Ground water investigations
 - a. Position of the water table relative to the ground surface
 - b. Fluctuations in water table levels
 - c. Salinity of ground water
5. Irrigation practices and requirements.
 - a. Quality of irrigation water
 - b. Frequency and type of irrigation
 - c. Amount of water applied each irrigation
 - d. Leaching requirement and deep percolation loss
 - e. Field ditch losses
 - f. Source of water supply
6. Investigation of existing subsurface drainage systems

A short discussion of the above listed surveys and investigations is given in the following sections. More details can be obtained from the references cited.

Topographic surveys

Topographic surveys of varying degrees of detail are normally required for both surface and subsurface drainage. In the case of subsurface drainage, topographic maps are needed as a base map to which ground water and soils information can be referenced. Information on ground water levels can be tied-in to the topographic survey, which will give a direct relation between surface elevation and water-table levels.

Seep areas and vegetation indicative of seasonal or deep seated sources of seepage or prolonged high-water table should be located on the map. Particular attention should be given to the elevation of control points such as ridges, knolls, low pockets, natural drainageways, rock outcrops, and outlet channels.

Drainage investigations in irrigated areas and seep areas of non-irrigated lands may require complete topographic coverage. The amount of detail required will vary with the complexity of the surface relief. Normally this detail will need to be such that maps can be prepared with a contour interval in the range of one to five feet. Provisions should be made to tie in piezometers and/or observation wells. Their location and elevation should be obtained along with other topographic data.

In a few cases, the required location of subsurface drains may be so apparent that detailed topographic coverage of the entire area under investigation may not be necessary. In these cases partial or strip topography along the proposed routes of the drain or drains may be adequate. This may be obtained through profile and cross-section surveys, along the routes of the drains.

Soils investigations

Standard soil surveys are needed for all areas being planned for subsurface drainage. These surveys are currently available in many areas, but if not, the best soils map available should be used. Additional information is usually needed, however. Soil borings to approximately one and one-half times the estimated depth of drain are needed to determine depth and thickness of the different soil materials, estimation of permeability of the different soil strata, location of layers of very low permeability and other materials which should be considered in design. These layers may include clay pans, shale, sandstone, bog iron, rock, gravel or quicksand. Such materials may require inclusion of filters, gravel envelopes, or special backfill treatment in design of the system.

The pH of the soil and the amount of sulfates present will have an effect on kinds of drain materials that can be used. Borings needed to furnish this information are described below under "Subsurface explorations." Information on characterization of soil materials and their structure and permeability is contained in the USDA Soil Survey Manual (3). Engineering properties of soils are described and requirements for investigations are covered in NEH Section 8, Engineering Geology.

The drainage of saline and alkali soils in irrigated areas must give attention to their particular requirements. For this reason it is necessary to delineate saline and alkali areas and determine the degree of salinity or alkalinity. In some areas this has been done in connection with standard soil surveys and is noted on soil maps. Where this has not been done it is necessary to make these determinations along with other investigations for drainage. In all cases it is desirable to obtain the services of a soil scientist or geologist to delineate and classify salty lands. If this is not possible, samples should be taken and submitted to a testing laboratory. Agriculture Information Bulletin No. 279 (4) provides a guide to the sampling procedure. It is recommended that for fields of 40 acres or less, two sampling sites be selected in areas which are apparently affected and two sites in unaffected areas. Samples should be taken to the plow depth and at 12-inch depths thereafter.

The U. S. Salinity Laboratory has developed a portable test kit for the purpose of determining salinity and alkalinity in the field. It is assembled in a small suitcase for convenience in transportation to field locations. Use of the kit is described in USDA Circular No. 982 (5). Operation is not difficult and does not require the services of a soil scientist.

Subsurface explorations

Subsurface drains in arid irrigated areas are usually placed at a depth of 6 to 9 feet below the ground surface; and in humid areas the drains are usually placed from 3 to 6 feet below the surface. Ground water flows to the drains through the soil and subsoil materials extending from the water table surface to a depth of several feet below the drain. (See "Principles of flow in the saturated zone," Chapter 1.) The depth of this region of flow will vary with the hydraulic conductivity of the subsurface materials present. For this reason it is necessary to explore these materials to a depth of about one and one-half times the drain depth, or deeper, to determine if there is a significant change in the hydraulic conductivity.

Logging soils and subsurface materials

Subsurface explorations are usually made by boring test holes on a rectangular grid pattern to cover the area under consideration. The spacing of borings should be based on a knowledge of soils, local geology and experience gained in a particular work area. Borings must be spaced close enough to permit the correlation of subsurface strata. In alluvial materials where sediments are heterogeneous materials deposited in a complex pattern, this spacing may need to be 100 feet or less. In areas of residual homogeneous soils the spacing may be as great as 1,000 feet. In practical field application the usual procedure is to select a grid spacing based on previous experience; start subsurface explorations and attempt to correlate the data from the borings progressively. If the correlation between borings is poor or lacking, the data should be supplemented by cutting the original grid spacing in half and repeating the correlation process. It often develops that in certain parts of an area correlation may be good, whereas in other sections it may be poor. In this latter case the grid pattern should be supplemented with additional borings to the extent that the subsoil and substrata configuration is made clear. Borings on large areas should be located on a grid pattern, usually rectangular. The lines of borings may be oriented in any convenient direction to fit the area. When the spacing and grid pattern have been established, guide stakes can be placed at field boundaries and interior stakes sighted in. If a topographic survey is to be made, the locations of borings can be tied in with it.

The depth of borings should be at least 1-1/2 times the drain depth. Since the actual depth of the drain which may be installed as a result of the investigations is not known, the borings are normally made to a depth of approximately twice the average drain depth in the area. A few deeper borings - 15 to 20 feet - interspersed with the others, should be made to determine the composition of underlying strata. The presence of certain types of strata may require the alteration of the entire drainage plan. If initial borings in the area indicate a rather uniform configuration of subsurface layers, the spacing of the borings may be increased.

Each boring should be numbered and identified by that number on the topographic map. Logs of each boring should be prepared in the field and identified by number and location. A sample sheet for logging the soils is given in Figure 2-1.

Information which should be recorded for all borings includes:

1. State, soil conservation district, work unit, farm or project, and location.
2. Name of technician logging the hole.
3. Date.
4. Boring number.
5. A stratigraphic description of the subsoil profile.
6. Estimated hydraulic conductivity of each significant layer.
7. Location of water table at time of boring.

Although a few borings may be made by hand auger, power equipment should be provided where many, and/or deep, borings are needed.

LOG SHEET FOR SOIL BORING

State _____ SCD _____ Work Unit _____

Farm or Project _____ Location _____

Technician _____ Date _____

Boring No. _____ Location _____

Soil Symbol _____ Land Use _____ Crop Condition _____

Log-Feet

0	12
1-	13-
2-	14-
3-	15-
4-	16-
5-	17-
6-	18-
7-	19-
8-	20-
9-	21-
10-	22-
11-	23-
12-	24-

Classification Symbol

GW – Gravel, well graded
 GP – Gravel, poorly graded
 SW – Sand, well graded
 SP – Sand, poorly graded
 CH – Clay, high plasticity
 CL – Clay, low plasticity
 MH – Silt, medium plasticity
 ML – Silt, low plasticity
 GC – Clayey gravels, plastic
 GM – Silty gravels, non-plastic
 SC – Clayey sands, plastic
 SM – Silty sands, non-plastic
 OH – Organic clays, plastic
 OL – Organic silts, non-plastic
 Pt – Peat & Muck

Wetness

1 – Dry 3 – Wet
 2 – Moist 4 – Saturated

Estimated Permeability

(S) less than 0.20 in/hr (MS) 0.20 to 0.80 in/hr
 (M) 0.80 to 2.50 in/hr (MR) 2.50 to 5.00 in/hr
 (R) 5.00 in/hr or more

Note: Show symbol to indicate the sediment type, number for wetness and circled letter for permeability.

Example: A slowly permeable wet clay with low plasticity would be logged as shown.

Remarks:

CL
3
(S)

Figure 2-1, Sample form for soil log

The Unified Soil Classification System is recommended for use in logging the soil materials. The Unified Soil Classification Symbols are defined as follows:

- GW - Well-graded gravels and gravel-sand mixtures, little or no fines.
- GP - Poorly graded gravels and gravel-sand mixtures, little or no fines.
- GM - Silty gravels, gravel-sand-silt mixtures.
- GC - Clayey gravels, gravel-sand-clay mixtures.
- SW - Well-graded sands and gravelly sands, little or no fines.
- SP - Poorly graded sands and gravelly sands, little or no fines.
- SM - Silty sands, sand-silt mixtures.
- SC - Clayey sands, sand-clay mixtures.
- ML - Inorganic silts, very fine sands, rock flour, silty or clayey fine sands.
- CL - Inorganic clays of low to medium plasticity, gravelly clays, sandy clays, silty clays, lean clays.
- OL - Organic silts and organic silty clays of low plasticity.
- MH - Inorganic silts, micaceous or diatomaceous fine sands or silts, elastic silts.
- CH - Inorganic clays of high plasticity, fat clays.
- OH - Organic clays of medium to high plasticity.
- PT - Peat, muck and other highly organic soils.

Based on Visual-Manual Procedure, ASTM D 2488

A visual-manual procedure for description of soils is given in ASTM Designation D 2488, and laboratory methods for classification of soils for engineering purposes is given in ASTM Designation D 2487.* Field tests and estimates of the hydraulic conductivity (HC) should be related to similar soils where the HC has been measured in place and to laboratory measurements of the HC on undisturbed samples of similar soils.

Check lists have been developed for description and field identification of soil materials, based on the Unified Soil Classification System. See Figures 2-2 and 2-3. These lists may be printed on double-weight field-book size paper for field use.

Soil samples for laboratory testing

Soil samples for use in laboratory analysis are needed for benchmark soils in each particular drainage problem area. Each significantly different stratum in a soil profile should be sampled for the laboratory tests. These tests generally should include hydraulic conductivity, and in special cases development of moisture retention curve, total pore space, mechanical analysis, and determination of organic matter. Undisturbed samples are necessary for the hydraulic conductivity, moisture retention, and pore space tests. Disturbed samples are suitable for the others. Various types of equipment have been developed for taking in-place samples. Taking the samples in an open pit has the advantage that a sample may be taken from a horizontal or a vertical direction, in order to obtain both horizontal and vertical hydraulic conductivity.

In arid irrigated areas disturbed samples should also be taken for testing the salinity of the soil solution extract. The first of these should be taken of the topsoil to the plow depth and others at depth increments of approximately one foot to the maximum depth of root zone (4). A small--1/2 pound--sample is adequate.

*American Society for Testing and Materials, 1916 Race Street, Philadelphia, Pa. 19103

DESCRIPTION OF FINE-GRAINED AND PARTLY-ORGANIC SOIL - ASTM D 2488				
<p>1. <u>Typical Name</u>: Sandy Silt Silt Clayey Silt Sandy Clay Silty Clay Clay Organic Silt Organic Clay</p> <p>2. <u>Maximum Particle Size</u>: Note percentage of boulders and cobbles in total sample.</p> <p>3. <u>Size Distribution</u>: Approximate percent gravel, sand and fines in fraction finer than 3 in. (76 mm)</p> <p>4. <u>Dry Strength</u>: None Very Low Low Medium High Very High</p> <p>5. <u>Dilatancy</u>: None Slow Rapid</p> <p>6. <u>Plastic Thread</u>: Weak and Soft Medium Stiff Very Stiff</p> <p>7. <u>Plasticity of Fines</u>: None Slight (low) Medium High</p> <p>8. <u>Color</u>: Use common terms or Munsell notation. Based on moist or wet condition.</p> <p>9. <u>Odor</u>: None Earthy Organic May be neglected except for dark-colored soils.</p> <p>10. <u>Moisture Content</u>: Dry Moist Wet Very Wet</p> <p>11. <u>Consistency</u>: Soft Firm (Medium) Stiff Very Stiff Hard</p> <p>12. <u>Structure</u>: Stratified Laminated (Varved) Fissured Slickensided Blocky Lensed[†] Homogeneous (Nonstratified)</p> <p>13. <u>Cementation</u>: Weak Strong</p> <p>14. <u>Origin</u>: Examples - Alluvial, Residual, Loess, Lacustrine, etc.</p> <p>15. <u>Group Symbol</u>: Estimate if desired. See Classification Chart, Fig. 1, ASTM Method D 2487.</p> <p>Example: <u>Clayey Silt</u>, some fine sand. Maximum size about 0.5 mm. About 10 percent fine sand, 90 percent slightly plastic fines. Yellowish brown (10 YR 5/6). Dry. Firm. Nonstratified, but with numerous vertical root holes. Strong reaction to HCl. Loess (ML).</p>				
FIELD IDENTIFICATION OF CONSISTENCY OF FINE-GRAINED SOILS*				
Consistency	Identification Procedure	Penetrometer tons/ft. ² or kg/cm ²	Std. Penetration Test Blows/ft. (ASTM D 1586)	
Very Soft....	Loses shape under its own weight	Less than 0.25	< 2	
Soft.....	Easily penetrated several inches by thumb	Less than 0.25	2 - 4	
Firm (medium)	Penetrated several inches by thumb with moderate effort	0.25 to 0.50	4 - 8	
Stiff.....	Readily indented by thumb, but penetrated only with great effort	0.50 to 1.00	8 - 15	
Very Stiff...	Readily indented by thumbnail	1.00 to 2.00	15 - 30	
Hard.....	Indented with difficulty by thumbnail	Over 2.00	> 30	
*Based on saturated soils.				
FIELD IDENTIFICATION OF FINE-GRAINED SOIL FRACTIONS FROM MANUAL TESTS				
Typical Name (Unified Class)	Dry Strength	Dilatancy Reaction	Toughness of Plastic Thread	Plasticity Description
Sandy Silt (ML)....	None - Very Low	Rapid	Weak - Soft	None - Slight (low)
Silt (ML).....	Very Low - Low	Rapid	Weak - Soft	None - Slight (low)
Clayey Silt*.....	Low - Medium	Rapid - Slow	Medium Stiff	Slight - Medium
Sandy Clay (CL)....	Low - High	Slow - None	Medium Stiff	Slight - Medium
Silty Clay (CL)....	Medium - High	Slow - None	Medium Stiff	Medium - High
Clay (CH).....	High - Very High	None	Very Stiff	High
Organic Silt (OL)..	Low - Medium	Slow	Weak - Soft	Slight
Organic Clay (OH)..	Medium - Very High	None	Medium Stiff	Medium - High
*Unified class ML applies to the first ratings; MH applies to the second ratings.				

Figure 2-2, Check list for fine-grained and partly organic soils

FHWA-RD-77-275, PP. 1-20

Further information on sampling and testing soils for analysis of salinity and alkalinity is given in Agriculture Handbook 60 (6) and USDA Circular No. 982 (5).

Hydraulic conductivity

The terms "hydraulic conductivity," "permeability" and "coefficient of permeability," although having different technical meanings, are often used in the same sense. The "coefficient of permeability" is defined (7) as the rate of flow of water through a unit cross-sectional area under a unit head during a unit period of time. The term "hydraulic conductivity" may be defined (8) as the coefficient K in Darcy's law $v = Ki$ where v is the velocity of seepage and i is the hydraulic gradient. Values of K depend on properties of the fluid, such as viscosity, as well as that of the porous medium, and reflect any interactions of the fluid with the porous medium such as swelling of soil and its attendant reduced porosity. The term "permeability" is used in a general sense to indicate the relative ability of soils to transmit water. In the following discussion the term "hydraulic conductivity" (HC) will be used in the specific sense to mean the rate of transmissibility of water through soil assuming a hydraulic gradient of unity.

In the past, much research work has been done on developing various methods and techniques for determining the permeability of soils. In general, these methods and techniques fall into two types depending on whether the soil was tested "in place" or whether soil samples were transported to the laboratory for testing. Tests made "in place" are generally considered superior as it is almost impossible to obtain samples and transport them to the laboratory without disturbing them to some degree, thereby altering their permeability.

Laboratory-testing methods involve placing soil samples in permeameters where they are subjected to a head of water for a designated period of time. By measuring the amount of water that passes through the sample in a given period of time the permeability can be determined.

Laboratory tests may be made in either of two ways. An undisturbed core may be obtained in the field with a special core sampler and taken to a laboratory for tests or a disturbed sample may be obtained and taken to the laboratory where it will be dried, reduced to granule size, and then packed into a permeameter tube for testing. Equipment for permeability tests is relatively inexpensive and may be purchased complete or fabricated locally. Tests and equipment are described in USDA Agriculture Handbook 60 (6) and USDA Technical Bulletin No. 1065 (7).

In-place measurement of permeability may be made by several methods. The procedures which have been used most commonly are described in Special Publication SP-SW-0262 of the American Society of Agricultural Engineers (9). In addition to a brief description of the different methods of measuring saturated hydraulic conductivity of soils, the equipment required is listed and the merits and limitations of each method are discussed. A list of references for details on theory and application is given.

The auger-hole method is the simplest method for measuring the hydraulic conductivity of soil in place in the presence of a water table. It is also one of the most reliable methods. Several investigators have contributed to the development of the theory and application of the method and a large part of their work is summarized by Luthin in Vol. VII of Agronomy Monographs (10) and by Kirkham (11). A good discussion of the method and equipment required is given by Van Beers in Bulletin No. 1 of the International Institute for Land Reclamation and Improvement, Wageningen, the Netherlands. Graphs, in metric units, are given for solution of the formula (12).

The number of tests which are needed to arrive at the value for hydraulic conductivity to use for design depends on the uniformity of the soil profile below the water table. This test, then, should be made after the soils have been logged or concurrently with the logging. It is a matter of judgment as to how many tests for HC should be made. The HC may vary quite a bit within short distances. Since it is desired to determine the average HC for a rather large area it is better to run several tests in different locations than to try to determine the HC in only one place. A good guide to go by is to use alternate logging holes for making tests of hydraulic conductivity. The number of logging holes and HC tests required are thus both related to the uniformity of the subsurface materials.

Other field permeability test methods are presented in NEH Section 8, Engineering Geology, and NEH Section 18, Ground Water.

Auger-hole method. - The principle of the auger-hole method is simple. A hole is bored to a certain distance below the water table. This should be to a depth about one foot below the average depth of drains. The depth of water in the hole should be about 5 to 10 times the diameter of the hole. The water level is lowered by pumping or bailing and the rate at which the ground water flows back into the hole is measured. The hydraulic conductivity can then be computed by a formula which relates the geometry of the hole to the rate at which the water flows into it.

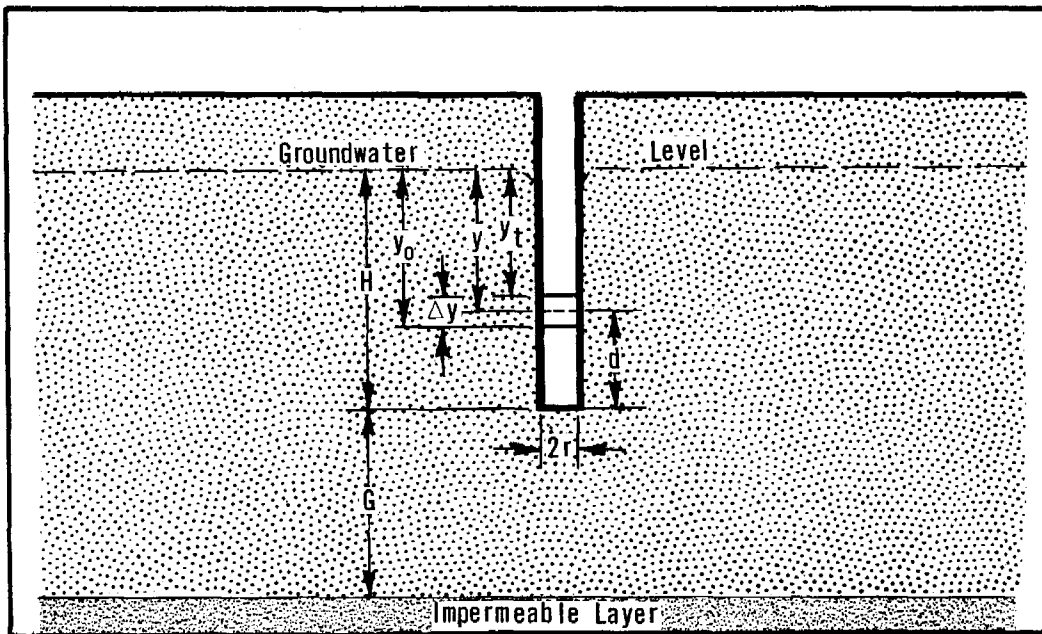

Figure 2-4, Symbols for auger-hole method of measuring hydraulic conductivity

K = hydraulic conductivity--inches per hour

H = depth of hole below the ground water table--inches

r = radius of auger hole--inches

y = distance between ground water level and the average level of water in the hole--inches, for the time interval Δt --seconds

Δy = rise of water--inches, in auger hole during Δt --seconds, time interval

G = depth of the impermeable layer below the bottom of the hole--inches. Impermeable layer defined as a layer which has the permeability of about one-tenth or less of the permeability of the layers above.

d = average depth of water in auger hole during test--inches

Good judgment is needed in determining how big a drawdown of the water level in the auger hole to make for the purpose of the test. Generally, a larger drawdown should be made for slowly permeable soils than for more permeable soils. A small drawdown for holes in sloughing soils may reduce the amount of sloughing. Pumping should stop when the water level is within a few inches of the bottom of the hole to prevent picking up sand in the pump.

Measurement of the rate of recovery of water in the auger hole should be completed before one-fourth of the total amount of drawdown has been recovered (10). Four or five readings should be taken at uniform short time intervals and a plot of the readings made to determine a uniform rate of recovery to use in the formula. Plottings of time in seconds against the residual drawdown in inches will indicate those readings at the beginning and end of the test which should be discarded and the proper values of Δt and Δy to use.

Equipment for auger-hole method. - - The equipment required to make the test consists of a suitable auger, a pump or bail bucket to remove water from the hole, a watch, and a device for measuring the depth of water in the hole, as it rises during recharge. For use in unstable soils a well screen may be necessary.

Many operators prefer a well made, light weight, boat or stirrup pump. One that is easily disassembled for cleaning is better. One type of pump which has given good service is a small double diaphragm barrel pump. This can be mounted on a wooden frame for ease of handling and use. The watch must have a second hand. For the depth measuring device a light weight bamboo fishing rod marked in feet tenths, and hundredths with a cork float works well. Other types of floats have been developed also. A juice can with a standard soldered to one end to hold a light weight measuring rod is good. A field kit for use in making the auger hole measurement of HC is illustrated in Figure 2-5. In addition to the items indicated on this figure, a watch and a soil auger will be needed.

In making the auger-hole measurement in fluid sands a perforated liner for the hole will be needed to keep the hole open and maintain the correct size. Several types of liners have been used. These include perforated or slotted downspouting (conductor pipe for roof runoff) and various types of well points and well screens, including a particular type of copper screen made in the Netherlands. For most kinds of fluid sands and silts this last screen is the best. It stays open much better than other types in these soils. For many soils the slotted downspouting is satisfactory, if adequate slot openings are provided to allow free flow into the pipe.

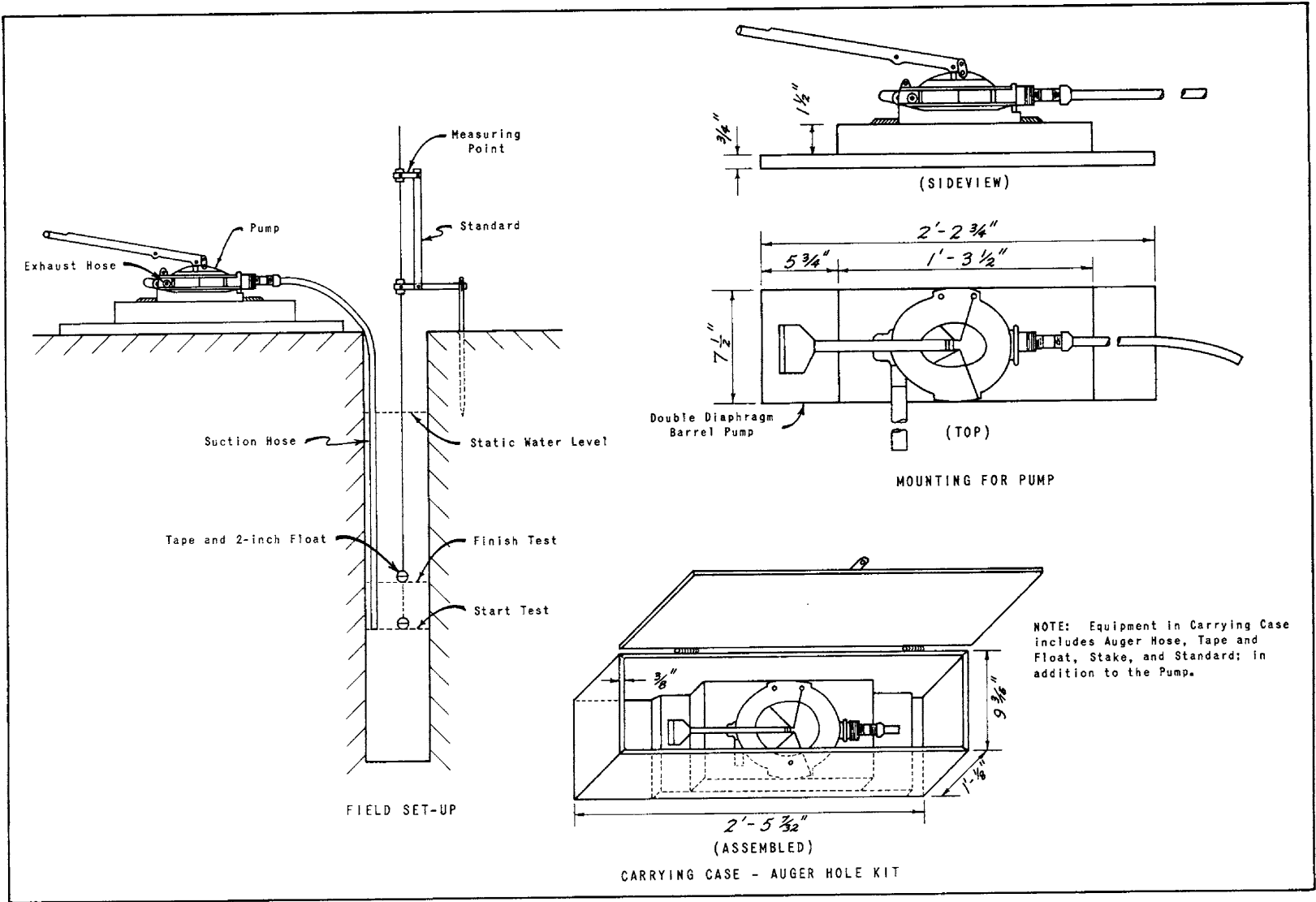

Figure 2-5, Equipment for auger-hole method of measuring hydraulic conductivity

FIELD MEASUREMENT OF HYDRAULIC CONDUCTIVITY AUGER-HOLE METHOD

For use only where bottom of hole coincides with barrier.

SOIL CONSERVATION DISTRICT Dry River WORK UNIT Salt Flat
 COOPERATOR John Doe - Farm No. 2 LOCATION 1/2 Mi. E. Big Rock Jct.
 SCD AGREEMENT NO. 264 FIELD NO. 4 ACP FARM NO. B-817
 TECHNICIAN Tom Jones DATE 1 June 64
 BORING NO. 4 SALINITY (EC) SOIL — WATER 5.6 ESTIMATED K 1.0 in/hr

START 10:03 ELAPSED TIME	Δt	DISTANCE TO WATER SURFACE FROM REFERENCE POINT			Δy	RESIDUAL DRAWDOWN
		BEFORE PUMPING	AFTER PUMPING	DURING PUMPING		
		B	A	R	A-R	R-B
SECONDS	SECONDS	INCHES	INCHES	INCHES	INCHES	INCHES
xx	xx	43	xx	xx	xx	xx
0.0	xx	xx	81.5		0.00	38.5
30				79.0		36.0
60				77.5		34.5
90				76.0		33.0
120				74.0		31.0
150	150			72.0	9.5	29.0

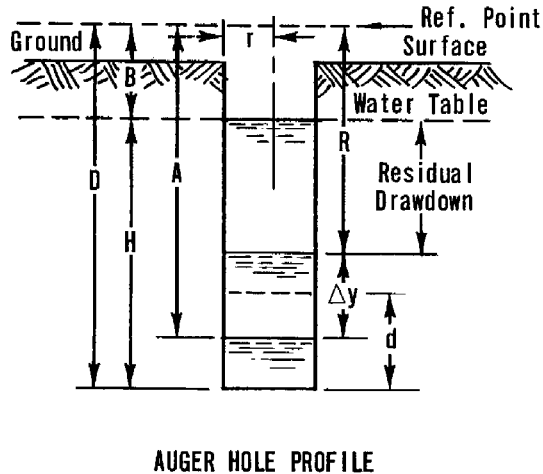
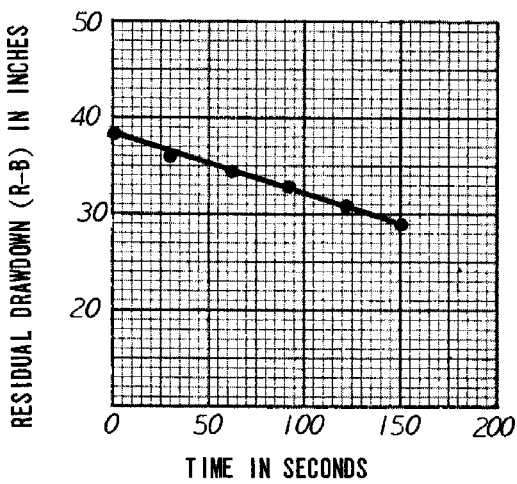

Figure 2-6--sheet 1 of 2, Auger-hole method of measuring hydraulic conductivity

Soil profile log holes are used for the test or a special hole may be augered for the purpose. The hole is pumped or bailed out 2 or 3 times to permit any puddled-over pores on the wall of the cavity to be flushed out by the in-seeping groundwater. This flushing process can be accomplished with a pump or bail bucket slightly smaller than the auger hole. The water level in the auger hole is allowed to become static following the cleaning process.

TEST: The water level is lowered in the hole with the pump or bail bucket. The distance the water level is lowered will be dependent on the sloughing tendency of the profile. Where sloughing is a problem a smaller drawdown should be used and possibly a liner or screen will be required. The water levels and time elapsed since beginning observations are recorded on the form. The rate of rise is used in the following formula to calculate K. The depth of water in the auger hole (D-B) should be about 5 to 10 times the diameter of the hole. Measurement of the rate of rise should be completed before $\Delta y \geq 1/4 (A-B)$.

$$K = 2220 \frac{r}{SH} \times \frac{\Delta y}{\Delta t}$$

K = Hydraulic conductivity in inches per hour

r = Radius of auger hole in inches

S = Function from figure on chart below

H = Depth of water in auger hole in inches (D-B)

Δy = Raise of water level in inches in Δt timed interval (A-R)

Δt = Time required to give Δy in seconds

d = Average depth of water in auger hole during test (D-A + $\Delta y/2$) in inches

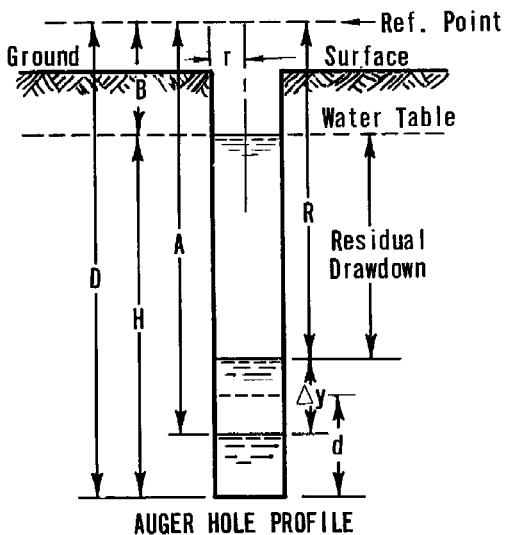

AUGER HOLE PROFILE

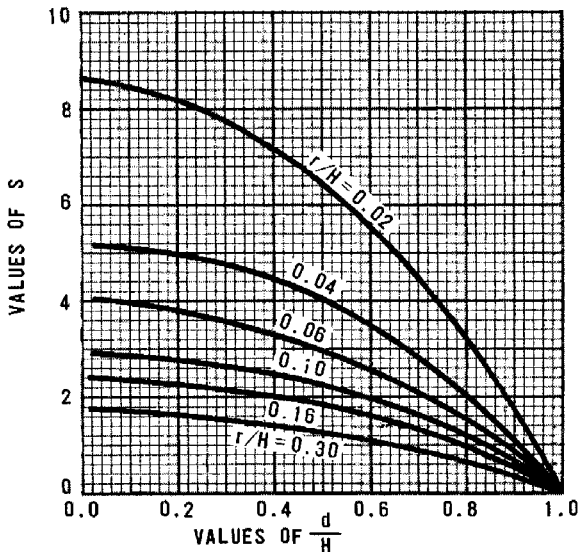

Hole Dia. $\frac{4''}{84''}$ Ground to Ref. = 11"

Hole Depth $\frac{93''}{2}$

$D = \frac{93''}{2}$

$r = \frac{2}{50}$

$H = \frac{50}{17}$

$d = \frac{17}{9.5}$

$\Delta y = \frac{9.5}{150}$ seconds

$\Delta t = \frac{150}{2}$ / $\frac{50}{50} = \frac{0.04}{0.32}$

$r/H = \frac{16.2}{50} = \frac{0.32}{9.5}$

$S = \frac{4.7}{2} \times \frac{9.5}{150}$

$K = 2220 \times (4.7) (50) \times \frac{9.5}{150}$

$K = 1.2 \text{ in/hr}$

Figure 2-6--sheet 2 of 2, Auger-hole method of measuring hydraulic conductivity

The openings in the screen should not restrict flow appreciably. The head loss through the screen should be negligible and the velocity of flow through the openings should be small - 0.3 foot per second or less - to prevent movement of fines into the hole. These criteria will usually be met if the area of openings is 5 percent or more of the total area of the screen.

The Bureau of Reclamation uses 4-inch downspouting with sixty 1/8 inch by 1-inch slots per foot of length. This works well in a variety of soils. The screen from the Netherlands referred to is made from a punched brass sheet 2 mm. thick with holes averaging about 0.5 mm. diameter. It is rolled into a tube 8 cm. in diameter by 1 meter long. The reasons this screen works so well are that the sheet is rolled so that the direction in which the holes are punched is outward and the holes are variable in size. It has been used in many troublesome soils and there have been no reports of clogging or failure to keep fines out of the hole.

Formulas for determination of HC by auger-hole method. - - Determination of the hydraulic conductivity by the auger-hole method is affected by the location of the barrier or impermeable layer. For the case where the impermeable layer coincides with the bottom of the hole a formula for determining the hydraulic conductivity (K) has been developed by Van Bavel and Kirkham (13).

The formula is as follows:

$$K = \left(\frac{2220r}{SH} \right) \left(\frac{\Delta y}{\Delta t} \right) \quad (\text{Eq. 2-1})$$

Where S is a function dependent on the geometry of the hole, the static depth of water and the average depth of water during the test (14), and the other symbols are as defined on page 2-29.

A sample form for use in recording field observations and making the necessary computations is illustrated in Figure 2-6. This includes a chart for determining the geometric function S for use in the formula for calculation of the HC.

The more usual situation is where the bottom of the auger hole is some distance above the barrier. Formulas have been developed by Ernst (15) for computing the hydraulic conductivity in homogeneous soils by the auger-hole method for both cases. Converted to English units of measurement the formulas are as given below. Refer to Figure 2-4.

1. For the case where the impermeable layer is at the bottom of the auger hole, $G = 0$:

$$K = \frac{15,000r^2}{(H + 10r)(2 - y/H) y} \frac{\Delta y}{\Delta t} \quad (\text{Eq. 2-2})$$

2. For the case where the impermeable layer is at a depth $\bar{y} = 1/2H$ below the bottom of the auger hole:

$$K = \frac{16,667r^2}{(H + 20r)(2 - y/H) y} \frac{\Delta y}{\Delta t} \quad (\text{Eq. 2-3})$$

To obtain acceptable accuracy from use of this method the following conditions should be met:

$$2r > 2-1/2 \text{ and } < 5-1/2 \text{ inches}$$

$H > 10$ and < 80 inches

$y > 0.2 H$

$G > H$

$\Delta y \leq 1/4 y_0$

Charts have been prepared for solution of Equation 2-3 for auger holes of $r = 1\text{-}1/2$ and 2 inches. For the case where the impermeable layer is at the bottom of the auger hole the hydraulic conductivity may be determined from these charts by multiplying the value obtained by a conversion factor "f" as indicated on Figure 2-7, Sheet 2 of 2.

Other methods for determining hydraulic conductivity. - A method for determining the hydraulic conductivity in the absence of a water table has been developed by Bouwer (16). This is termed the double-tube method for field measurement of hydraulic conductivity of soil above a water table. The principle, method, and equipment required are discussed in the reference. Resulting measurements are less precise than measurements in a water table due to slow adjustments that must take place from capillary movement and air entrapment within the soil-pore space.

A field test for determining the permeability of soil in place and termed the Well Permeameter Method is used by the Bureau of Reclamation (17). This method, consisting of measuring the rate at which water flows outward from an uncased well under constant head, is particularly useful for estimating the need for lining an irrigation canal prior to construction. The apparatus required for the test and the procedure are described in the Bureau's Earth Manual.

Ground-water investigations

The purpose of a ground-water investigation is to provide information on the position and fluctuation of the water table at various points in the problem area. This will determine the extent and severity of the drainage problem over the area and will indicate the general type and location for subsurface drains. To obtain information on the position and fluctuation of the water table to develop a ground-water or piezometric pressure head contour map, it is necessary to establish observation wells and/or piezometers. Conditions of artesian flow should be investigated by use of batteries of piezometers.

It may be necessary to install a few observation wells just outside and adjacent to the project area to determine ground-water levels and water-table fluctuations in the perimeter area.

Observation wells

These are open wells placed at strategic points throughout the problem area to permit periodic observations of water-table levels. They may be cased or uncased wells depending on the stability of the soil materials at each location. Wells should be established on a grid pattern and spaced to give a close approximation of the ground-water surface. Observation wells should be established concurrently with making soil borings and measuring hydraulic conductivity. A number of the borings made should be cased--if necessary--and used as observation wells.

Size of wells and casing. - It is usually necessary to case observation wells so that they may be maintained for a period of at least one year. The purpose is to prevent sloughing and caving. Casing material may be sheet metal, downspouting, stovepipe, drain tile or tubing, wood, used well casing or pipe, or standard commercial types of well casing. Downspouting serves the purpose very well as it

HYDRAULIC CONDUCTIVITY BY AUGER HOLE METHOD FROM FORMULA ERNST

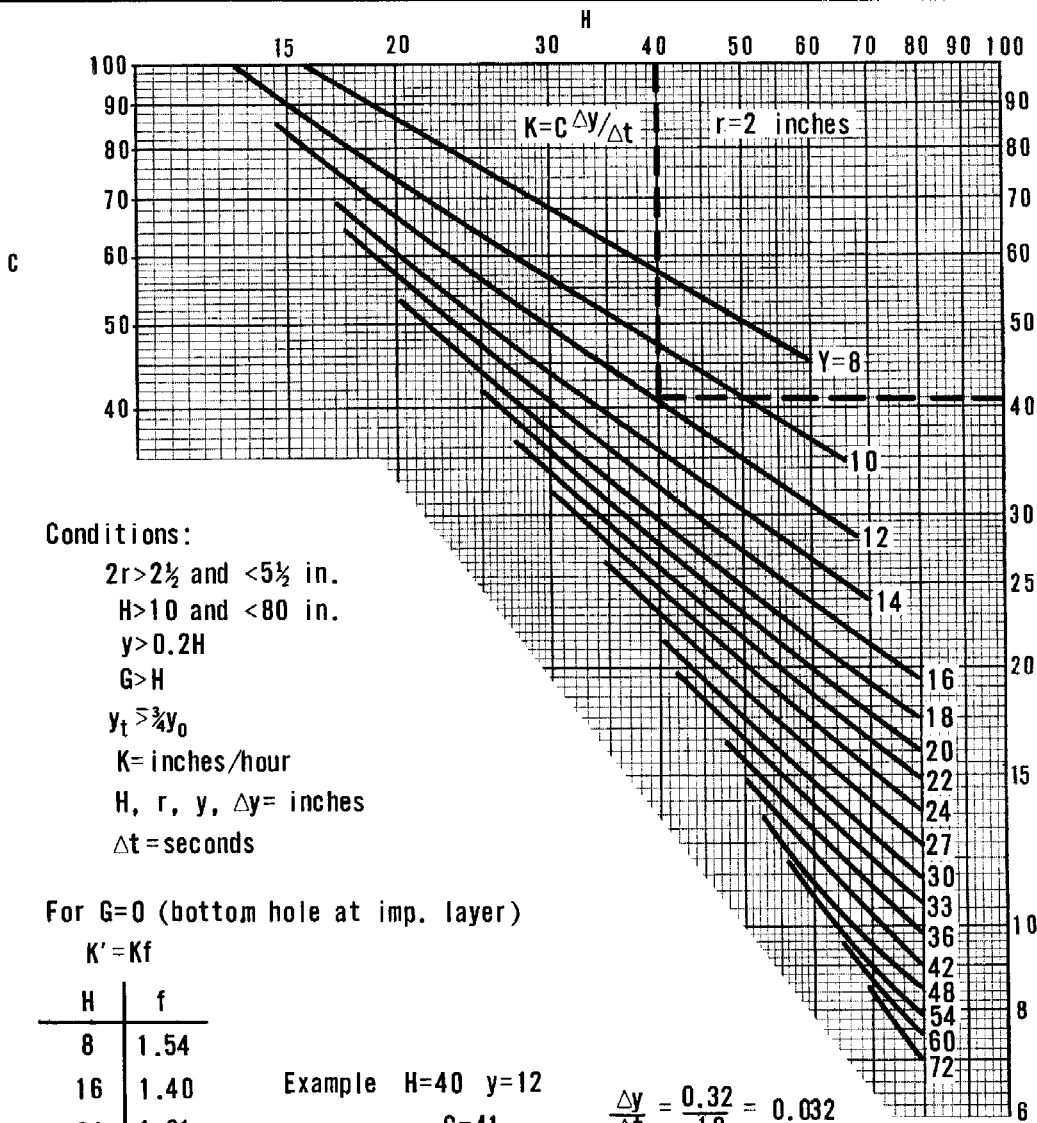

Conditions:

- 2r > 2½ and < 5½ in.
- H > 10 and < 80 in.
- y > 0.2H
- G > H
- y_t > ¾ y₀
- K = inches/hour
- H, r, y, Δy = inches
- Δt = seconds

For G=0 (bottom hole at imp. layer)

K' = Kf

H	f
8	1.54
16	1.40
24	1.31
36	1.22
48	1.16
60	1.13
72	1.10

Example H=40 y=12

C=41

$$\frac{\Delta y}{\Delta t} = \frac{0.32}{10} = 0.032$$

$$K = 41 \times 0.032 = 1.31 \text{ in/hour}$$

REFERENCE From formula L. F. Ernst Groningen, The Netherlands

$$K = \frac{16,667r^2}{(H+20r)(2-\frac{y}{H})y} \frac{\Delta y}{\Delta t}$$

U. S. DEPARTMENT OF AGRICULTURE
SOIL CONSERVATION SERVICE
ENGINEERING DIVISION - DRAINAGE SECTION

STANDARD DWG. NO.
ES-734
SHEET 1 OF 2
DATE 3-23-71

Figure 2-7, Hydraulic conductivity--auger-hole method by Ernst Formula

HYDRAULIC CONDUCTIVITY BY AUGER HOLE METHOD FROM FORMULA ERNST

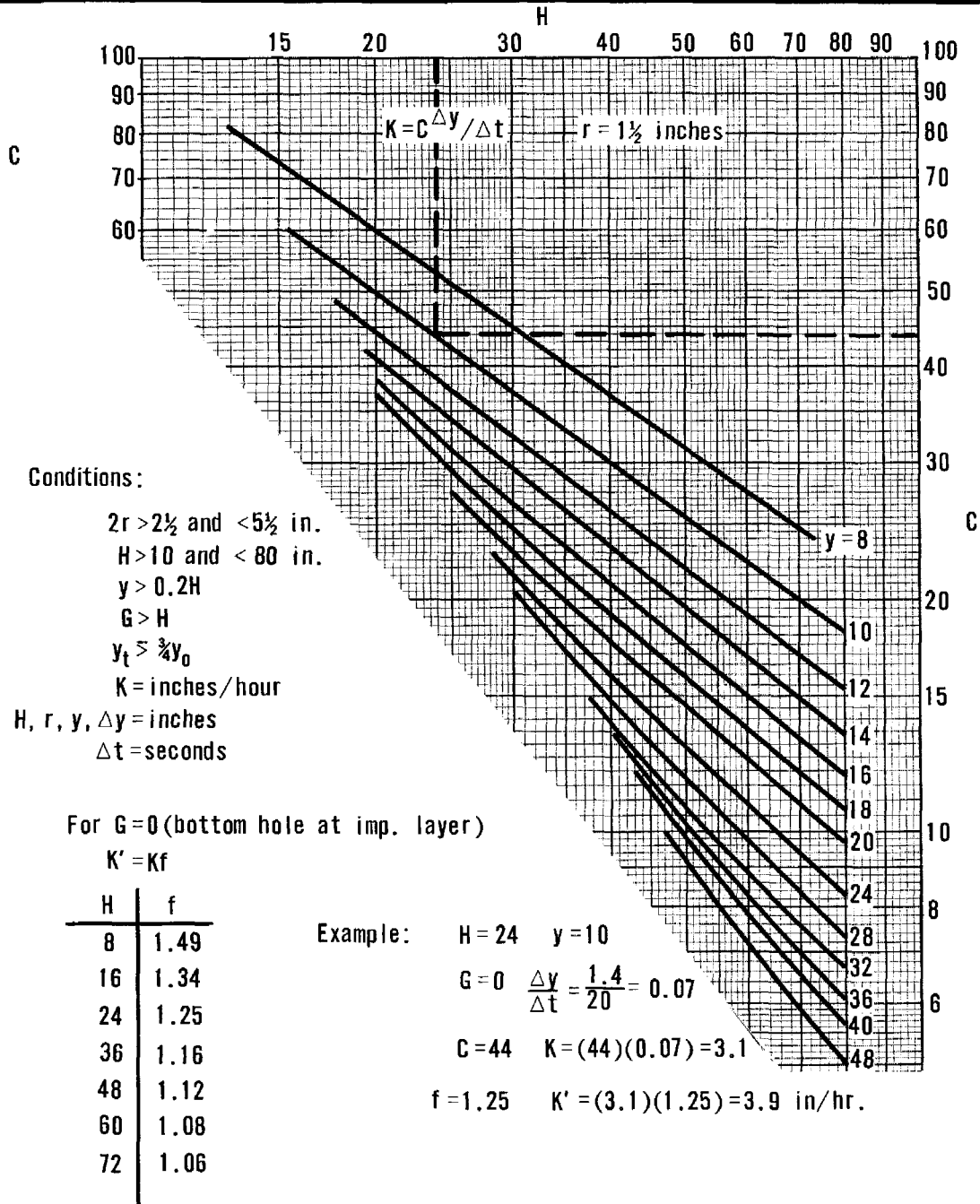

REFERENCE From formula L. F. Ernst
 Groningen, The Netherlands

$$K = \frac{16,667r^2}{(H+20r)(2-\frac{y}{H})y} \frac{\Delta y}{\Delta t}$$

U. S. DEPARTMENT OF AGRICULTURE
 SOIL CONSERVATION SERVICE
 ENGINEERING DIVISION - DRAINAGE SECTION

STANDARD DWG. NO.
 ES - 734
 SHEET 2 OF 2
 DATE 3 - 23 - 71

Figure 2-7--sheet 2 of 2, Hydraulic conductivity--auger-hole method by Ernst Formula

is sufficiently durable, cheap, light in weight, easy to handle, and can be installed with simple hand tools. The casing should extend at least 8 inches above the ground surface and be provided with a cap for protection.

Water surface fluctuations within large diameter observation wells often lag considerably behind actual water-table fluctuations in slowly permeable soils because of the relatively large water storage within the well. Reducing the well diameter reduces the water storage factor and the lag error. A small diameter observation well can be installed by using an adaptation of jetting techniques described under piezometers page 2-43. A 3/4-inch inside diameter pipe is jetted to a depth of 15 feet. Then a 3/8-inch outside diameter perforated tube is placed inside the larger pipe. The 3/4-inch pipe is pulled leaving the smaller tube in place, and the annular space around the tube is back-filled with coarse sand. The 3/8-inch perforated tube then functions as a small diameter well. In unstable soils a larger outside pipe should be used and the sand placed in the space between it and the tube before pulling it.

Small diameter jetted wells have functioned satisfactorily and have several advantages over the larger wells. They can be installed to much greater depths; installation is quicker; the cost of materials is reduced; and the lag error is considerably less.

Spacing. - The spacing of observation wells usually will be some multiple of the spacing for borings, as previously discussed. In areas where the subsurface profile is fairly uniform, the water-table surface usually is smooth without abrupt changes.

Generally, the water-table surface is smoother than the land surface. For these reasons, it is often possible to correlate water-table levels between observation wells that are spaced farther apart than soil borings. There should be no set rule for spacing observation wells as this should be a "cut and try" process as the investigation proceeds. The investigator should compare water-table levels observed in the wells and if there is a sharp departure from the general slope of the water-table surface, additional wells should be established to explain the irregularities.

Depth. - The depth of observation wells should be based on the expected low ground-water level. The purpose of the wells is to permit measuring the seasonal high and low ground-water levels within certain limits. Therefore, it is necessary to estimate what the low level will be. Soil profile and stratification also may indicate the proper depth for observation wells. Generally, a water level below 8 feet is not significant in drainage planning and wells to this depth are usually adequate except where artesian conditions exist.

Establishing well elevations. - In order to correlate water-table levels with ground-surface levels and to compile ground-water contour maps, the elevation of observation wells must be determined. Surveys are made to determine the elevation of the ground-surface at the location of each well and of the measuring point. The well casing usually provides a good measuring point.

Measuring water table levels and recording data. - Periodic measurements should be made to show the distance from the measuring point to the water-table level in each well. These measurements must be tabulated and reduced to show the actual elevation of the water level and to show the depth from the ground surface to the water level in each well. Forms which may be used for recording measurements are illustrated on Figure 2-8. A simple device for use in observation wells to obtain the maximum and minimum water elevations, which may occur between the readings, has

WELL ~~or~~ PIEZOMETER RECORDS
FOR DRAINAGE INVESTIGATIONS

Property A. B. Doe
Location S¹/₂ Sec. 10-T5N-R8E
Technician R. B. Roe B. M. Elev. 2876.84

NO.	ELEV. (Reference)	DATES (Readings Taken)					
		3-2-71		4-6-71		5-4-71	
		READ.	ELEV. W. S.	READ.	ELEV. W. S.	READ.	ELEV. W. S.
A-1	2872.6	4.6	2868.0	4.1	68.5	4.0	68.6
A-2	2871.4	3.0	68.4	2.8	68.6	2.8	68.6
A-3	2872.5	2.5	70.0	2.3	70.2	2.1	70.4
A-4	2875.0	*1.1	73.9	5.0	70.0	4.8	70.2
etc.	"	"	"				
"	"	"					
"	"						
"	"						

REMARKS

*Surface water near well-?
Level notes in Book-13

WELL ~~or~~ PIEZOMETER RECORDS
FOR DRAINAGE INVESTIGATIONS

Property A. B. Jones
Location N.E. ¹/₄ Sec. 6-T10N-R3W
Technician R. B. Roe B. M. Elev. 1242.98

NO.	ELEV. (Reference)	DATES (Readings Taken)					
		3-2-71		4-6-71		5-4-71	
		READ.	ELEV. W. S.	READ.	ELEV. W. S.	READ.	ELEV. W. S.
E-3	1238.4	6.8	1231.6	5.4	33.0	6.4	32.0
E-4	1239.2	7.2	32.0	6.6	32.6	6.8	32.4
etc.	"	"					
"	"						
"							

REMARKS

Piez. all in good condition.
Level notes in Book-28

Figure 2-8, Example of field sheets for well and piezometer records

been developed by two Corps of Engineers employees, Beryl G. Stinson and John G. Collins. The device is known as the "Max-Min Well Gage" and it can be shop made for about \$10 to \$20. Figure 2-9 illustrates the gage and details its construction.

The principle of the gage is simple. The float--refer to Figure 2-9--moves freely on the shaft; consequently, as the water table rises, the top slide is moved up the shaft by the float, and as the water table recedes, the bottom slide is moved down the shaft by the float. Field procedures used in reading the gage are as follows:

1. Pull the nylon line up until the sinker hits the bottom of the float and the line is fairly taut.
2. Clamp the line at the top of the cap.
3. Lift the entire gage assembly from the well.
4. Measure the position of the two slides and the float on the rod (the rod may be marked with a mark-a-lot pencil, and the position of the slides and float can then be read directly).
5. Push the slides flush with the top and bottom of the float assembly.
6. Lower the entire gage assembly back into the well.
7. Lower the nylon line until the sinker just rests on the spacer.
8. Clamp the line at the top of the cap.

Period of measurement. - Observation wells should be established to function for a period of at least one year. In irrigated areas with permeable subsoil and substratum sediments, water-table levels fluctuate considerably during the growing season. Fluctuations of as much as 8 feet are common. Under these conditions, any one set of measurements usually will not furnish the information needed on high and low water elevations. For this reason, a series of measurements must be made, usually one or two each month, for a period of several months to a year. When the max-min well gage is used, readings may be less frequent. By comparing the data by months, the highest water-table condition can be detected. This is the critical condition and should be used as a basis for drainage design.

Piezometers

The piezometer (7) is a useful tool in determining ground-water conditions, particularly where artesian pressures are suspected. There is a basic difference between a piezometer and an observation well. The piezometer is a small-diameter pipe driven into the subsoil so that there is no leakage around the pipe and all entrance of water into the pipe is through the open bottom. The piezometer indicates only hydrostatic pressure of ground water at the specific point in the soil where the lower end or opening of the tube is located. In the case of observation wells, the entrance of water into the well is through the entire section penetrated below the water table. The observation well reflects a composite of all ground-water pressure to the depth of the well.

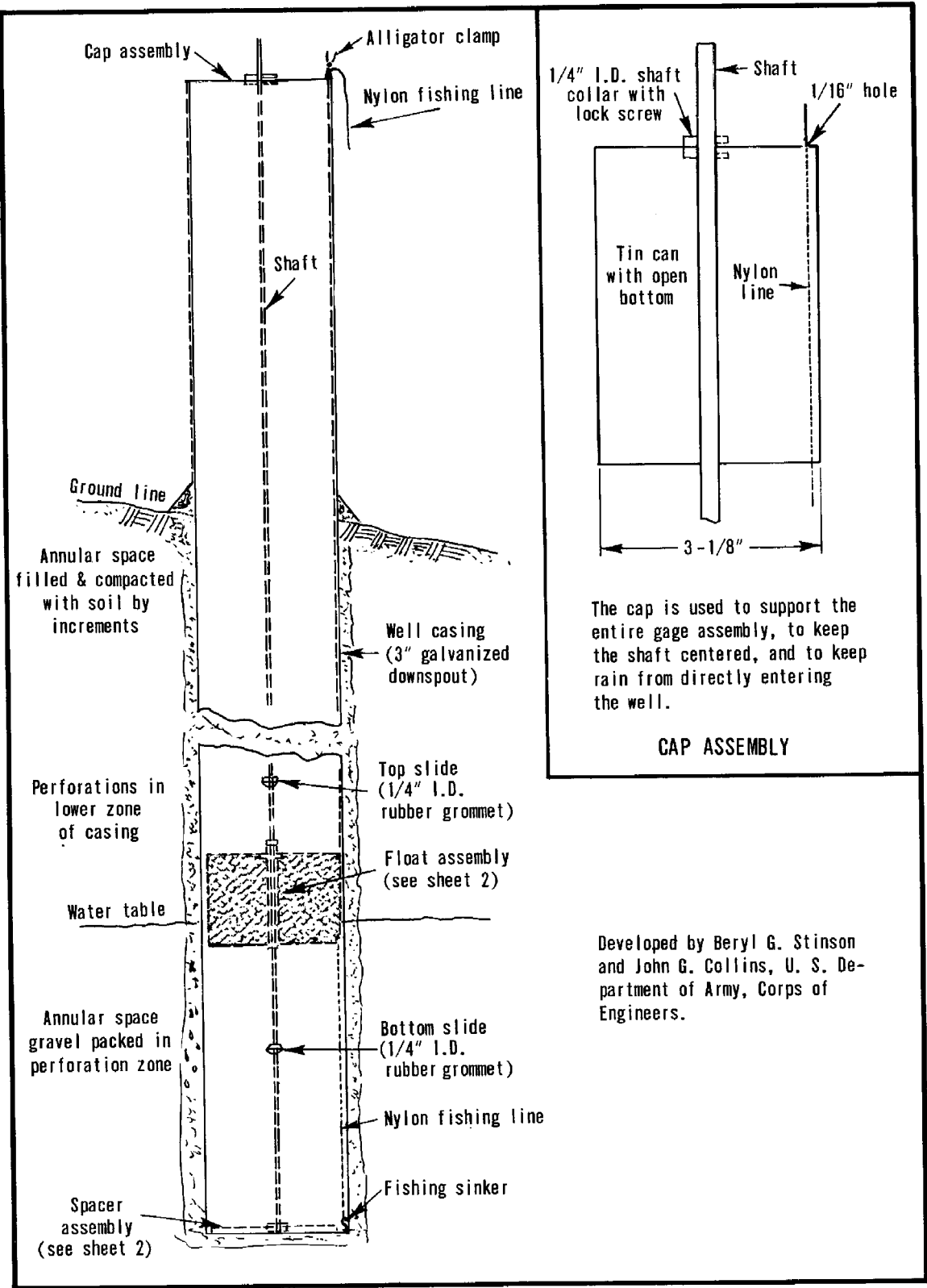

Figure 2-9, Max-min well gage

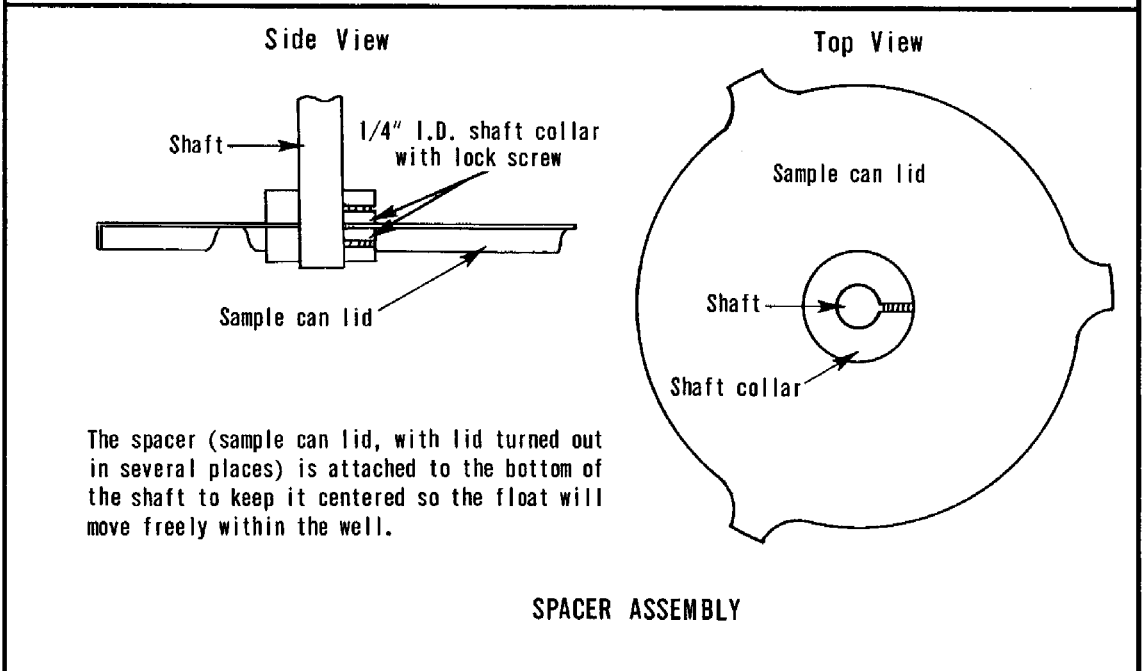
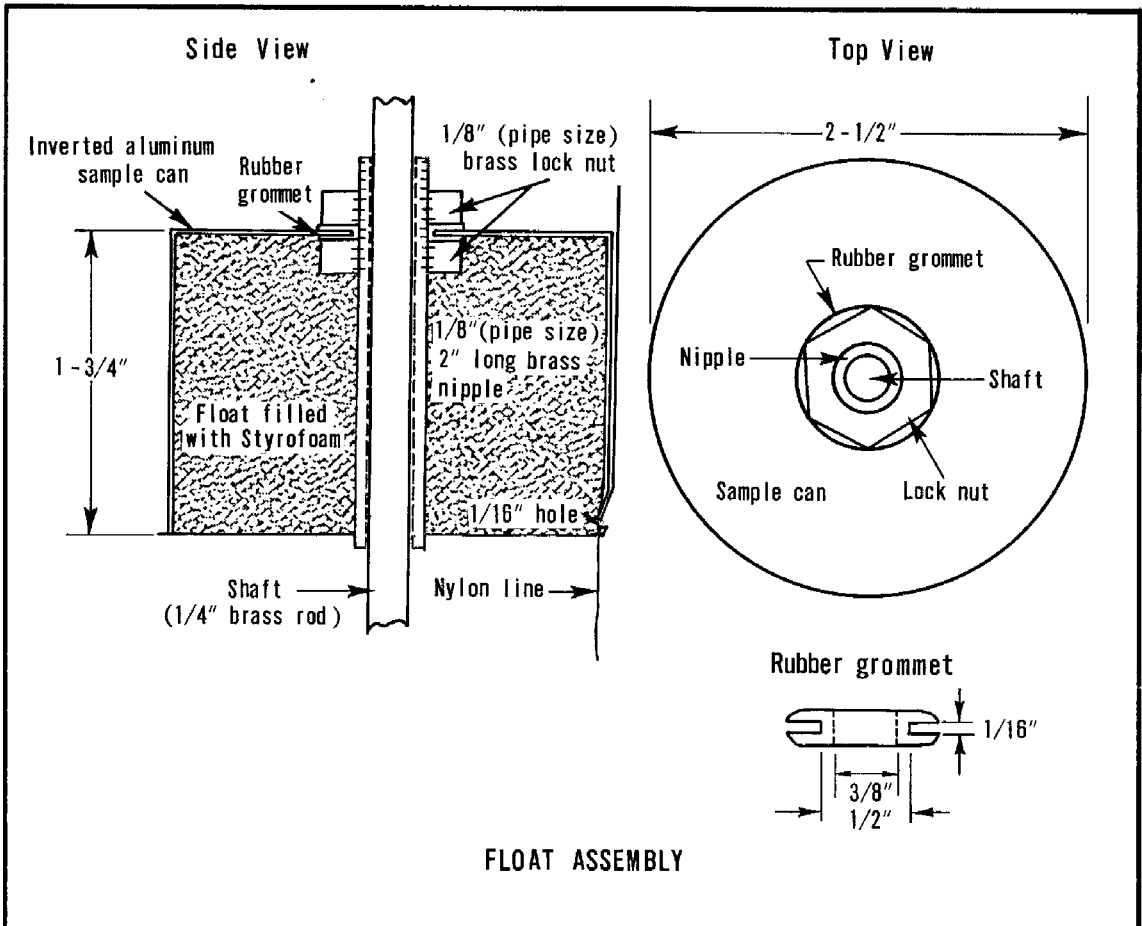
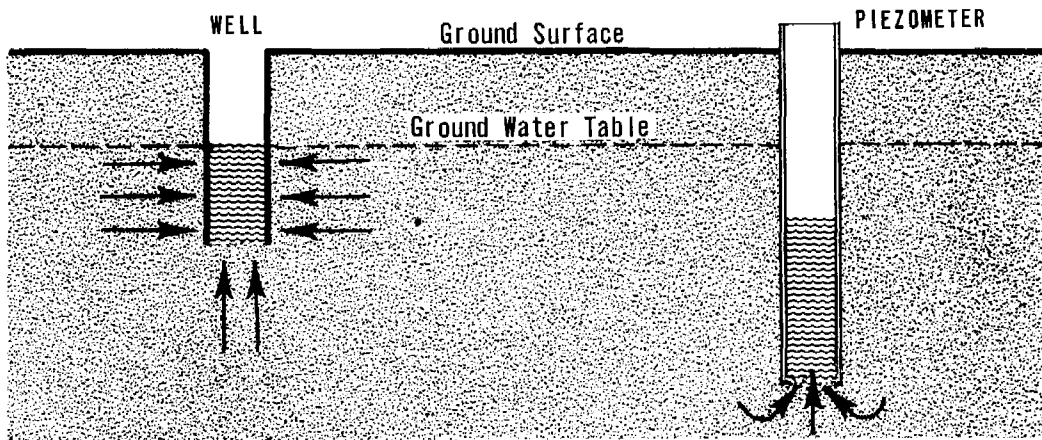
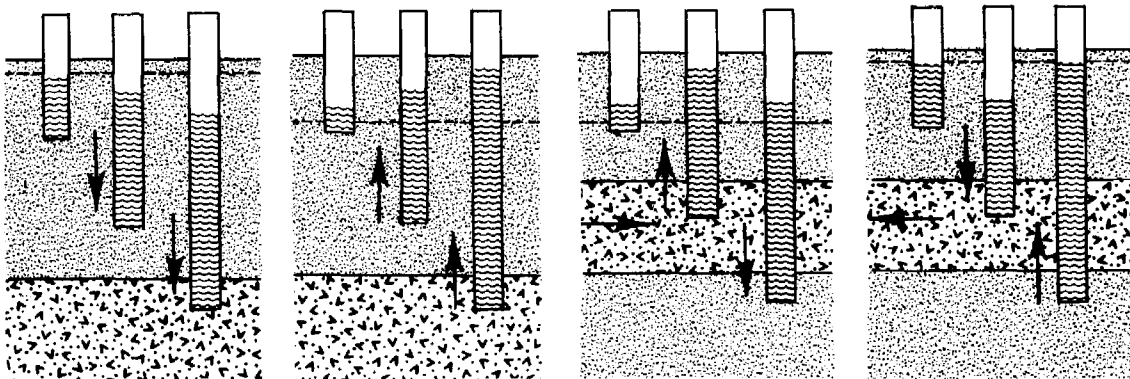

Figure 2-9--sheet 2 of 2, Max-min well gage



As the piezometer is a tool that can be used to determine the hydrostatic pressure at a point in the soil profile, it is valuable in detecting artesian pressures and differences in pressure between various strata. Ground water moves from a point of high hydrostatic pressure to one of low pressure; therefore, the flow of ground water can be charted if the various hydrostatic pressures are known. Batteries of piezometers of different lengths can be used to detect the vertical movement of ground water, and piezometers spaced at horizontal intervals can be used to detect horizontal seepage or movement. This technique is especially useful in studying ground-water movement adjacent to canals, drains, and reservoirs.



The piezometers indicate that the ground water is going down and that there is some natural drainage.

The piezometers indicate a hydrostatic pressure or that there is water coming up from a deeper strata.

The piezometers indicate a hydrostatic pressure in a stratum, and that water is being forced both up and down from the stratum.

The piezometers indicate that ground water is moving into a stratum and going out of the area.

Piezometers may be installed by driving or by jetting into position by high velocity water jet. If more than just a few piezometers are to be installed the jetting technique is recommended.

Installation by driving. - Before driving the tube is started, a loose rivet is placed in the lower end of the 1/4-, 3/8-, or 1/2-inch pipe to keep soil from entering. The exact length of the pipe should be noted so that the elevation of the bottom of the pipe after driving may be determined. When the desired depth is reached, a rod is inserted and the rivet is punched out, leaving an open pipe--or piezometer.

There are several types of piezometer drivers available. One type is a special hammer fashioned like a steel fence-post driver. It consists of two pieces of 3/4-inch pipe, one 15 inches long and the other 5 feet, joined by a 1-foot section of 1-1/2-inch pipe filled with lead. This leaded section is fitted with a steel plug at each end to receive the impact of the blow. The piezometer is driven into the soil with the driver until it reaches the desired depth. Since hand driving of a 15- or 20-foot piezometer in some formations may entail considerable labor, the use of this method is definitely limited. Placing a joint and coupling about 1 foot from the bottom of the pipe slightly enlarges the hole through which the pipe passes. This helps to reduce side friction and cuts down on driving resistance. Piezometers may be driven to about 40 feet with a pneumatic jack-hammer if the top of the piezometer pipe is fitted with a driving cap.

For successful installation and operation of piezometers, the soil at the lower end of the piezometer should be removed by flushing a small cavity at the bottom of the pipe. The equipment needed for flushing includes a water container, stirrup pump, and enough plastic tubing to reach the bottom of the deepest piezometer. The piezometer is tested for sensitivity by filling the piezometer with water and observing the rate of drop. If the rate of drop is very slow, the flushing should be repeated.

See Figure 2-10 for an example of a form for recording information on installation of piezometers. Figure 2-8 illustrates a form for recording readings.

Installation by jetting. - Equipment required for jetting piezometers into position consists of a high pressure pump, a supply of water, and the necessary fittings to make the connections for directing the jet of water through the piezometer. Commercial orchard spraying rigs have been used successfully for the pump and water supply tank, and the fittings added have been varied according to the ingenuity of the people developing the equipment and the convenience and ease of operation desired (18).

As the piezometer is jetted into position and to the depth desired by the high velocity water jet the sediments dislodged and suspended in the water flow to the surface by the passage around the pipe. An experienced operator can examine the flow of these sediments and by correlating the characteristics of the materials with the "feel" of the pipe as it is jetted into position he can develop a reasonably good log of the profile.

Installation of piezometers by jetting in coarse sand or gravel requires the addition of drillers mud to the water used for jetting. If this is not done the water from the jet flows into the formation and the skin friction on the pipe becomes too great for it to be moved. In areas where this condition is present the equipment should include an additional water tank for mixture of the drillers mud. A pump will be needed for agitation of the mud, and additional fittings are required to permit utilization of either clear water or the water and mud mixture in the jetting operation.

OR-14
APP-3.7-55

U. S. DEPARTMENT OF AGRICULTURE
SOIL CONSERVATION SERVICE

PIEZOMETER LOG
FOR DRAINAGE INVESTIGATIONS

Property A. B. Doe Date 9-15-71
 Piezometer No. B-4 Elevation 3301.9
 Location Sec. 15-T21N.-R31E. Land Use Crop
 Surface Soil Clay Loam Elevation 3300.4
 Physiography Bench Relief Slope 0.003
 Length of Piezometer 9.0 Feet
 Height of Piezometer above Ground Surface 1.5 Feet
 Depth of Piezometer in the Ground 7.5 Feet
 Technician R. B. Roe

DRIVING RESISTANCE		PUNCHING RIVET FROM END OF PIEZOMETER (Resistance)				
H..... Hard M..... Moderate E..... Easy		Hard	Moderate	Easy		
0		<input type="checkbox"/>	<input checked="" type="checkbox"/>	<input type="checkbox"/>		
1		<hr/>				
2	E	SOIL CONDITION AT END OF PIEZOMETER (Soil on End of Punch Rod)				
3		Dry	Moist	Wet	Soupy	Water
4		<input type="checkbox"/>	<input type="checkbox"/>	<input type="checkbox"/>	<input type="checkbox"/>	<input checked="" type="checkbox"/>
5	EM	SOIL TEXTURE (Determined from Flushing Effluent)				
6		Clays	Silts	Loams	Fine Sands	Coarse Sands
7		<input type="checkbox"/>	<input type="checkbox"/>	<input type="checkbox"/>	<input checked="" type="checkbox"/>	<input type="checkbox"/>
8	M	RATE OF WATER SURFACE DROP IN PIEZOMETER (Following Flushing)				
9		Artesian	Back Pressure	Slow	Moderate	Rapid
10		<input type="checkbox"/>	<input type="checkbox"/>	<input type="checkbox"/>	<input checked="" type="checkbox"/>	<input type="checkbox"/>
11		<hr/>				
12		REMARKS				
13		Piez. elev. top of pipe at elev. 3301.9				
14						
15						
16						
17						
18						
19						
20						
21						

Figure 2-10, Example of field sheet for piezometer log

Batteries of piezometers. - In areas where artesian pressures are suspected piezometers should be installed in groups of 2 to 4 piezometers of different lengths. The number of piezometers in each battery will be dependent on the variations in the subsoil profile. A piezometer should bottom out in each stratum of significantly different permeability. Where the subsoil materials are essentially the same at least two piezometers should bottom out at different depths in order to determine the direction of water flow.

Salinity of ground water

Drainage investigations in arid and semi-arid areas should include an investigation of salinity. It is assumed that in irrigated areas the quality of irrigation water is known. If not, the quality should be determined. Investigation of soil salinity was discussed on page 2-21. To supplement the information obtained by that investigation samples of ground water should be obtained and tested for total salt content. These may be obtained from the bore holes used to measure hydraulic conductivity. A small one-ounce sample bottle of water is adequate for the test.

Irrigation practices

Irrigation and agricultural practices, quality of irrigation water, precipitation, and salinity are the principal factors which determine the drainage coefficient in an irrigated area. The procedure for making the determination is discussed in detail in Chapter 4. Information needed includes precipitation records, knowledge of crops to be grown, quality of irrigation water, salinity of the soil, the amount of water to be applied each irrigation, the frequency of irrigation and an estimate of irrigation water losses. The leaching requirement, necessary to the maintenance of a favorable salt balance, must be included in the water to be drained but it is not considered a loss. It should be considered a necessary use of water. The amount of irrigation water applied and the frequency of irrigation can be obtained from farmer-rancher interviews. In district or corporation type enterprises this information can usually be obtained from the project manager's office. Data on the leaching requirement and deep percolation losses can be obtained from an analysis of crops grown and irrigation water quality and from consumptive use studies in the local area. Data on field ditch losses can be obtained from actual measurements made, or may be available from irrigation project records. Field ditch losses are usually minor and vary in the general range of five to ten percent of the field delivery. In the absence of data on ditch losses they can usually be estimated at about eight percent without introducing serious error.

Investigation of existing systems of buried drains

Investigation of old drain installations is sometimes necessary to determine feasibility of rehabilitating or adding them to other systems, or using them as outlets for new systems. Often, investigation of such drains is almost entirely a probing and digging operation.

Prior to making the field investigation, it is desirable that all possible sources of information on the old system be explored. These would include old construction plans, records and diaries, and the comments of knowledgeable inhabitants. Soil surveys, farm conservation plans, and aerial photographs may reveal information also. Aerial photographs taken after heavy rainfall or periods of high water may reveal the general location of the system through lighter coloring of drier soils immediately over the drains or differences in color or density of vegetative growth.

By use of metal probes, exact location of lines can be found and inspection pits opened up along the line, usually at about 500-foot intervals. From these locations, the depth, grade and size of drain, amount of silt and root growth in it, and the condition of drain material can be appraised. Need for additional inspection pits is determined from what appears to be wrong with the drain. Poor grade, such as high and low places in the drain, would require closer spacing of pits than would uniform deposits of silt. Surface sinks over lines are indicative of broken tile or excessive construction gaps between tile. Rising water in an inspection pit would indicate blocks in the drain further downstream. If a few openings show cracked or broken tile, enough tile must be uncovered to determine whether the line should be salvaged.

If silt deposits occupy a substantial part of the drain cross section and extend throughout much of the line, consideration should be given to cleaning the line or to replacing it. Accumulation of chemical deposits, such as iron and manganese oxides, in the drain and drain openings also may make a drain ineffective. It is usually cheaper to install a new drain than to dig up, clean, and relay an existing small line. However, salvage of drains may be accomplished by cleaning the drain in place with special jetting equipment. This equipment uses high velocity water jets from a nozzle on a high pressure hose inserted in the line from the outlet end to dislodge and flush silt and sludge from the drain. Treatment with sulfur dioxide gas may be needed for rehabilitation of drains affected by chemical deposits. See Chapter 4, page 121.

Sufficient amounts of soil are exposed in the process of establishing inspection pits to provide checks on soil texture and drain spacing requirements.

Observation of the type of drain failure also indicates cause of failure. For example, longitudinal breaks at quarter points on the circumference of a tile drain are indicative of expansion of freezing water in the line or excessive loading.

Thus, inadequacies of design are revealed from the location, depth, grade and size of drain and absence of essential auxiliary measures, such as silt traps, etc. Poor alignment, wavy profile, and defective drains reveal inadequacy of construction and materials. Presence of sink holes, filled silt traps, and surface washes over lines may indicate inadequate design, lack of suitable filter around the drain, poor construction, and inadequate maintenance. Filled and overgrown outlet channels reveal inadequate maintenance.

References

- (1) MARMER, H. A.
1951. Tidal Datum Planes. U. S. Coast and Geodetic Survey, Special Publication No. 135, U. S. Government Printing Office.
- (2) DRAINAGE OF IRRIGATED LANDS COMMITTEE, SW-234, AMERICAN SOCIETY OF AGRICULTURAL ENGINEERS.
1966. Guide for Investigation of Subsurface Drainage Problems on Irrigated Lands. Special Publication SP-04-66, American Society of Agricultural Engineers, St. Joseph, Michigan 49085.
- (3) SOIL SURVEY STAFF, USDA, SOIL CONSERVATION SERVICE.
1951. Soil Survey Manual, USDA Agriculture Handbook No. 18, U. S. Government Printing Office.
- (4) BOWER, C. A.
1963. Diagnosing Soil Salinity. U. S. Salinity Laboratory, Agricultural Research Service, U. S. Department of Agriculture, Agriculture Information Bulletin No. 279.
- (5) RICHARDS, L. A., BOWER, C. A., and FIREMAN, MILTON.
1956. Tests for Salinity and Sodium Status of Soil and of Irrigation Water. Circular No. 982, U. S. Department of Agriculture.
- (6) UNITED STATES SALINITY LABORATORY.
1954. Diagnosis and Improvement of Saline and Alkali Soils. Agriculture Handbook No. 60, U. S. Department of Agriculture.
- (7) DONNAN, W. W. and BRADSHAW, G. B.
1952. Drainage Investigation Methods for Irrigated Areas in Western United States. Technical Bulletin No. 1065, U. S. Department of Agriculture.
- (8) KIRKHAM, DON.
Measurement of the Hydraulic Conductivity of Soil in Place.
Journal Paper No. J-2505, Iowa Agricultural Experiment Station, Ames, Iowa, Project 998.
- (9) DRAINAGE RESEARCH COMMITTEE, SW-231, AMERICAN SOCIETY OF AGRICULTURAL ENGINEERS.
1962. Measuring Saturated Hydraulic Conductivity of Soils. Special Publication SP-SW-0262, American Society of Agricultural Engineers, St. Joseph, Michigan 49085.
- (10) LUTHIN, JAMES N.
1957. Drainage of Agricultural Lands. Vol. VII of Agronomy Monographs, American Society of Agronomy, Madison, Wisconsin.
- (11) KIRKHAM, DON.
1965. Saturated Conductivity as a Characterizer of Soil for Drainage Design. Journal Paper No. J-5310, Iowa Agricultural Experiment Station, Ames, Iowa. Conference Proceedings, Drainage for Efficient Crop Production, American Society of Agricultural Engineers, St. Joseph, Michigan 49085.

- (12) VAN BEERS, W. F. J.
1958. The Auger Hole Method. Bulletin 1, International Institute for Land Reclamation and Improvement, Wageningen, the Netherlands.
- (13) VAN BAVEL, C. H. M. and KIRKHAM, DON.
1948. Field Measurement of Soil Permeability Using Auger Holes. Soil Science Society of America Proceedings, Vol. 13, pp 90-96.
- (14) SPANGLER, M. G.
1951. Soil Engineering. International Textbook Co., Scranton.
- (15) ERNST, L. F.
1950. A New Formula for the Calculation of the Permeability Factor with the Auger Hole Method. Agricultural Experiment Station, T.N.O. Groningen, the Netherlands. Translated from the Dutch by Herman Bouwer, Cornell University, Ithaca, N. Y., 1955.
- (16) BOUWER, HERMAN.
1962. Field Determination of Hydraulic Conductivity Above a Water Table with the Double-Tube Method. Soil Science Society of America Proceedings, Vol. 26, No. 4, July-August 1962.
- (17) UNITED STATES BUREAU OF RECLAMATION.
1963. Earth Manual. U. S. Department of the Interior, Bureau of Reclamation.
- (18) REGER, J. S., PILLSBURY, A. F., REEVE, R. C., and PETERSEN, R. K.
1950. Techniques for Drainage Investigations in Coachella Valley, California. Agricultural Engineering, Vol. 31, No. 11, pp. 559-564, November 1950, Journal of the American Society of Agricultural Engineers, St. Joseph, Michigan 49085.

APPENDIX A

TYPICAL OUTLINE FOR PRELIMINARY SURVEY

This typical survey outline illustrates the detail which is normally required for the engineering survey for development of a watershed work plan for a flat land watershed. The criteria listed is for illustration only, but it is typical for the following type of watershed:

1. Soils are slowly permeable. Permeability is generally less than 0.5 inch per hour.
2. Slopes are flat - less than four feet per mile.
3. The watershed is moderately well developed for agriculture. A large percentage is cultivated, with the rest in woodland, pasture, and miscellaneous.
4. Some drainage improvements have been made, but due to lack of organization and financing, maintenance has been neglected and the present drainage situation is poor.
5. Principal crops are rice, cotton, and soybeans.

OUTLINE FOR SURVEY
of the
CYPRESS BAYOU WATERSHED, SUTTON COUNTY
MIDDLESTATE
May 1971

I. Objectives:

- A. Determine extent of area needing flood prevention and drainage and adequacy of the outlet for desired improvements.
- B. Locate and design principal features of a flood prevention and drainage system which will remove within one day after cessation of rain the runoff from 48-hour, 2-year frequency storms.
- C. Estimate the quantities and costs of the improvements needed to meet the objective in B above.
 1. Break down the estimate into the part needed for group facilities (disposal system) and the part needed for on-farm improvements (collection system).
 - a. Group facilities should be extended to a minimum 160 acres drainage area, but not beyond the point where less than two landowners are benefited.
 - b. On-farm or collection system should include all facilities, other than those included as group facilities, which are needed to meet the objective listed above.

II. Data presently available:

(This is usually listed in the report of Preliminary Investigation. It is listed here as an example of the type of data which is useful on a survey of this type.)

- A. Aerial photographs, 1968 flight - 8"/mi. alternates and 3.167"/mi. consecutives (contact prints).

Complete coverage of the watershed.

B. Maps:

1. Sutton County Highway Map--scale 1/2 inch equals 1 mile.
2. U. S. Corps of Engineers quadrangle maps: DeQueen, 1954; Golden, 1941; Gilmer, 1935; and Vaness, 1935--scale 1/62,500--5' contour interval - complete coverage.
3. Cypress Bayou Watershed Map--scale 2 inches equals 1 mile.
4. Generalized soils map--Sutton County SCD--scale 1 inch equals 1 mile.
5. Approximately 60 percent coverage standard soil surveys.

C. Surveys:

1. U.S.C. & G.S., control leveling, first order--DeQueen West, Gilmer to DeQueen to Alton to Sanford, Sanford to Big Bayou, and Alton West.
2. U.S.C.E., BM data--DeQueen, Golden, Gilmer, and Vaness quadrangles.

D. Records and reports:

1. House Document No. ____, __th Congress 1st Session, Blue and Salt Rivers and Tributaries, Middlestate, 1967.
2. U.S.C.E. stream gage data--Big Bayou near Vaness, and at Big Bayou floodgate, U. S. Army Engineer District, Vicksburg.

III. Data to be developed:

- A. Land use and capability map.
- B. Drainage area map of watershed--to be added to Cypress Bayou Watershed Map. Watershed boundaries of all mains and laterals should be delineated.
- C. Project map of watershed--to show all principal features of the recommended plan of improvement.
- D. Land ownership map.
- E. Plans, profiles, cross sections, and other design data of all mains and laterals to be included in the plan of improvement.
- F. Design data for all appurtenant structures for mains and laterals and for other features of the plan of improvement for the watershed.

- G. Estimate of quantities and costs for all features of the plan.
- H. Report of the survey and investigation including recommendations and any information needed for work plan development. Data A - G inclusive to be attached as appendixes to the report.

IV. Proposed sequence of survey and investigation:

- A. From study of generalized and detailed soils maps and aerial photographs, determine land use, land capability, and area needing drainage.
 - 1. Information from standard soil surveys to be expanded to cover the watershed according to the generalized soils map and aerial photographs.
 - 2. Map to be prepared on Cypress Bayou watershed base map showing areas which will benefit from flood prevention and improved drainage. Tabulation of land use according to soils to be developed as basis for estimating benefits.
- B. By study of quadrangle maps and aerial photographs locate existing main ditches and principal laterals.
 - 1. Locate these on alternate contact-print aerial photographs. Identify each main stream or ditch by a Roman number. Also give each ditch its local name, if any. Number each lateral in a way which will identify it with its outlet.
- C. Locate, number, and give elevations of benchmarks within the watershed and vicinity on a county highway map. Data listed in IIC above to be included.
- D. Sketch watershed boundaries on the contact-print aerial photographs from data on quadrangle maps and aerial photographs. Check these boundaries on the ground as the survey progresses. Correct where necessary. Make a level survey where needed to delineate boundaries.
- E. Obtain data from U. S. Army Engineer District, Vicksburg, concerning outlet for Cypress Bayou into Big Bayou.
 - 1. From the Corps of Engineers study of water surface profiles - present and projected - for Big Bayou, for the two-year and five-year frequency storms, determine the adequacy of Big Bayou as the outlet for the proposed improvements.
- F. Establish additional temporary benchmarks (TBM's) on the North-South roads which are generally parallel to the main streams and along the east and west sides of the watershed. These TBM's are to be numbered and identified so they can be used in subsequent surveys.
 - 1. Locate TBM's at intervals of approximately 1 mile and at intersections with East-West roads.
 - 2. Close lines of differential levels with an allowable error of $\pm 0.05 \sqrt{\text{Length of line in miles}}$.

- G. Visually inspect all main and lateral ditch locations.
1. Estimate existing roughness coefficients of ditches which apparently have an adequate cross section.
 2. Check location of ditches previously sketched on aerial photographs - correct where necessary. Improve alignment as needed. Obtain necessary information on fences, irrigation flumes, dams, or any obstruction in the ditches which will affect the design or cost of the improvements. Record on aerial photographs or in notebook as required.
 3. Examine existing ditches for any evidence of instability - erosion or sedimentation.
 4. Estimate density and extent of clearing required for improving channel capacity.
 5. Locate and describe all utility lines crossing the ditches.
- H. Make a field survey.
1. Obtain cross sections of main ditches and laterals at intervals of approximately one mile; at major structures as bridges; where substantial changes in cross section or depth are evident; and below the entrance of all major tributaries. Take representative cross sections at each proposed realignment. Use the E - W roads to run levels to carry elevations from established TBM's to the locations selected for cross sectioning.
 2. Determine horizontal location of cross sections on mains and laterals by map wheel or scaling from aerial photographs. Measure from outlet upstream in miles to nearest hundredth. Cross sections must be accurately surveyed and located to be used with the design survey.
 3. Establish temporary benchmarks in strategic locations near the site of each cross section.
 4. Check previously located watershed divides, when running levels to obtain cross sections, and make corrections where needed.
 5. Determine the location, type, size, and condition of all bridges, culverts, and flumes on mains and laterals. Obtain cross sections, elevations of underside of stringers and bottom of footings, invert elevations of all culverts, and elevations of road surfaces at bridges and culverts. Information should be adequate to determine the adequacy of structure in its present condition or approximate cost of alteration or replacement if necessary.
 6. Determine high water elevations of main ditches and streams where possible.
 7. Obtain soil profile at each ditch cross section taken - - on mains to minimum depth of 10 feet; below intersection of Cypress and Muddy Bayous to minimum depth of 15 feet; and on all laterals to minimum depth of 6 feet. All depths given are below normal ground level.

- I. Plot existing cross sections and profiles of mains and laterals surveyed.
 1. For cross sections use horizontal and vertical scales of 1 inch equals 10 feet except for unusually large sections where a scale of 1 inch equals 20 feet, horizontally and vertically may be preferable. All sections should be located on cross-section sheet in the proper sequence. Scales used are to be clearly indicated. (Use 10 x 10 paper.)
 2. For profiles use a horizontal scale of 1 inch equals 2000 feet and a vertical scale of 1 inch equals 4 feet. (Use 4 x 20 paper.)
 3. On profiles show normal ground (low side), spot elevations and distances from ditch of control points, and existing ditch bottom. Plot the logs of soil borings. For structures plot the elevations of underside of stringers, roadbed, bottom of ditch under bridges or invert of culvert and bottom of structure footing. Give brief description of structures (as wood deck, concrete abutments, etc.) including size. Give type and estimate of riprap, if any.
- J. Complete location of mains and laterals on watershed map. Use corrected locations sketched on contact-print aerial photographs. Correct stationing as required. Add laterals and extend existing laterals to give coverage to watershed as outlined in ICl.a.
- K. Compute drainage areas at all cross-section locations.
- L. Determine rainfall excess - R_e - from a 2-year frequency, 48-hour storm and compute the C for the coefficient for surface drainage, $Q = CM^{5/6}$, by the relation $C = 16.39 + 14.75 R_e/2$.
- M. Compute capacity required at all cross -section locations based on the Cypress Creek Formula thus developed.
- N. Establish hydraulic gradelines for good drainage of the watershed, giving due consideration to water surface elevation of the outlet. (See Chapter 5).
- O. Complete design of drainage system.
 1. Check capacities of existing mains and laterals--including bridges and culverts--using the existing roughness coefficient. Evaluate the junctions of mains and laterals including the need for side inlet structures.
 2. Where existing sections are inadequate, compute the size required. Vary side slopes as required for stability, hydraulic efficiency and maintenance requirements. Proportion bottom widths and depth for best hydraulic efficiency, within requirements for channel stability.
 3. Based on soil characteristics determine stability of proposed channel by method of allowable velocities as prescribed in Engineering Standard for Open Channel, Code 582.
 4. Compute sizes of bridges and culverts which must be replaced. Design culverts to carry 25 percent more flow at the hydraulic grade line

than ditch is designed for. For bridge replacements, design bottom of stringers to be a minimum of one foot above the hydraulic grade line and the length to span the top width of proposed ditch.

- P. Plot the proposed sections superimposed on original cross sections and compute yardage of required excavation. Plot proposed bottom on profile. Add notes to profile concerning structure alterations or replacements necessary.
- Q. Estimate quantities and cost of the proposed improvement: clearing, clearing and shaping, channel excavation and disposition of spoil, bridges, culverts, grade stabilization structures, erosion control structures for side water inlets, watergates for cross fences, irrigation flumes, other appurtenant structures. Base estimate on current State standards and specifications.
- R. Estimate right-of-way required and show widths required by mile location on the profile sheet.
- S. Prepare report.

V. Personnel required. Field work to start 10/4/71

<u>Personnel</u>	<u>Dates</u>		<u>Man Days</u>
Engineer GS-13	9/7/71 - 1/21/72		4
Engineer GS-12	9/7/71 - 1/21/72	2 days/month	9
Engineer GS-11	9/20/71 - 1/21/72	2 days/week	36
Engineer GS-9 (Field and office 50-50)	9/27/71 - 1/7/72	Full time	75
Geologist GS-9	11/22/71 - 12/17/71	Full time	20
Aid GS-6 (Office)	9/27/71 -- 1/7/72	Full time	75
Aid GS-6 (Survey party)	10/4/71 - 12/17/71	Full time	55
Aid GS-5 (Survey party)	10/4/71 - 12/17/71	Full time	55
2 Aids WAE (Survey party)	10/4/71 - 12/17/71	Full time	110
2 Aids WAE (Geologist's helpers)	11/22/71 - 12/17/71	Full time	40
Complete field work	12/17/71		
Complete plotting, design, and estimates	1/7/72		
Complete report	1/21/72		

VI. Equipment. (Normally only equipment not on hand by the survey party will be listed. This list might be required to set up a new party.)

A. Automotive.

Pickup, equipped with trailer hitch, - Engineer GS-9

Station wagon - survey party

Truck w/power auger, fully equipped (See Guide to Geologic Site Exploration, South RTSC Area), Geologist GS-9

B. Boat and appurtenant equipment.

12-foot flat bottom aluminum boat on trailer

7-1/2 HP outboard motor

4 Life preservers

2 Oars - sounding weight - 200' steel wire, 11 ga.

C. Equipment for survey party.

1 Engineers' level, w/tripod and carrying case

2 - 14' Philadelphia level rods

1 - 100' steel tape

2 - 50' metallic tapes

1 - Tapewriter with aluminum tape

2 - Hand axes w/scabbards

2 - Pole axes, single bit

1 - 6-lb. sledge hammer

2 - Machetes w/scabbards

1 - Shovel, sharpshooter

6 - Aluminum hats, visor type

6 - pr. hip boots, (Lightweight, sizes to fit personnel)

Notebooks, pencils, lumber crayons, stakes, flagging material, 30d nails, water can, insect repellent, clip boards, carrying case for contact print aerial photographs, first aid kit, 10 pocket-type snakebite kits.

D. Office equipment.

1 - Drafting table, w/adjustable stool

1 - Calculator

1 - Slide rule

1 - Filing cabinet

1 - Desk and 10 chairs

2 - Tables

1 - Typewriter, with stand

Cross-section and profile paper, tracing paper, manila paper, pencils,
writing paper, straightedges, triangles, engineers scales, scratch pads.

E. Books.

National Engineering Handbook

Surveying: Theory and Practice, 5th Edition - Davis, Foote, and Kelly

King and Brater's Handbook of Hydraulics, Fifth Edition

Tables, Trigonometric, Peters

Hydraulic Tables - Corps of Engineers

Technical Bulletin 129, USDA, Flow of Water in Drainage Channels.

Developed at:

Slippery Rock Junction,
Middlestate
July 1, 1971

By:

Tom Jones, Engineering Specialist
John Doe, Planning Party Engineer
Robert Roe, Area Engineer

Approved:

Sam Smith, Planning Party Leader

